

Table of contents

	Page
Safety notes / Technical support	2
-----	-----
Introduction	3
-----	-----
Dimensions	4
-----	-----
Options	5
-----	-----
Technical data	6
-----	-----
Mounting	9
-----	-----
Electrical installation	12
-----	-----
Programming	14
-----	-----
Trouble shooting	18
-----	-----
Menu structure	19
-----	-----
Maintenance	21
-----	-----
Notes for use in Hazardous Locations	22
-----	-----
Disposal	24

Subject to technical change.
All dimensions in mm (inches).

We assume no liability for typing errors.
Different variations to those specified are possible.
Please contact our technical consultants.

Safety notes / Technical support

Notes

- Installation, maintenance and commissioning must be carried out only by qualified technical personnel.
- The product must be used only in the manner outlined in this instruction manual.

Special attention must be paid to warnings and notes as follows:



WARNING

Relates to a caution symbol on the product and means, that a failure to observe the necessary precautions can result in death, serious injury and/or considerable material damage.



WARNING

Relates to a caution symbol on the product: Risk of electric shock



WARNING

Used when there is no corresponding caution symbol on the product, means that failure to observe the necessary precautions can result in death, serious injury, and/or considerable material damage.

CAUTION

A failure to observe the necessary precautions can result in considerable material damage.

Safety symbols

In manual and on product

Description



CAUTION: refer to related documents (manual) for details.



Earth (ground) Terminal



Protective Conductor Terminal

Technical support

Please contact your local supplier (see www.uwt.de for address). Otherwise you can contact:

UWT GmbH
 Westendstr. 5
 87488 Betzigau
 Germany

Tel. 0049 (0)831 57123-0
 Fax. 0049 (0)831 76879
info@uwt.de
www.uwt.de

Introduction

NivoRadar® is a 2-wire, 78 GHz FMCW radar level transmitter for continuous monitoring of solids and liquids in silos and vessels.

Applications

Ideal system for all solids applications, including those with extreme dust and high temperatures to +200 °C (+392 °F).

- Powder, granulate, small or coarse bulk goods

Available for industries such as

- Food
- Grain
- Cement
- Plastics
- others

Function

The main benefits of using 78 GHz over devices using lower frequency are:

- Very narrow beam, so device is insensitive to mounting nozzle interference and vessel obstructions.
- Short wavelength yields very good reflection properties on sloped solids, thus a safe measurement is ensured.

The technology is very tolerant to buildup on the lens antenna, however an air purge inlet is provided for periodic cleaning if required. Signals are processed using Process Intelligence which has been field-proven in over 1,000,000 applications worldwide (ultrasonic and radar).

Features

Measurement range

- Up to 100m (329 ft)

Approvals

- Approval for use in both General and Hazardous Locations.

Mechanic

- Lens antenna and flange for quick and easy positioning.
- Stainless steel housing.
- Plane flanges and Aiming flanges.

Service

- Plug and play system, simple installation and commissioning.

Programming

- Configure via optional Plug on Display with push buttons.
Configuration with only 6 parameters.
Once programmed, the Plug on Display can be removed if desired and used to copy parameters to multiple units.
- Alternative configuration via HART possible.

Dimensions

Plane flange version

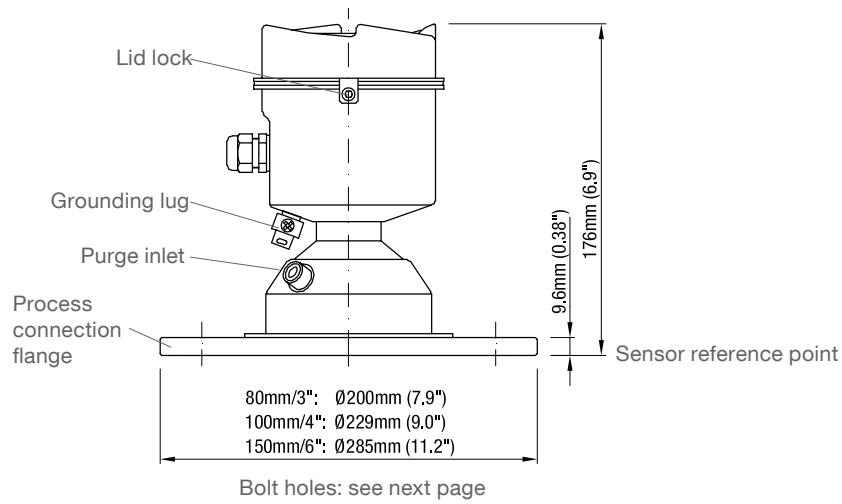

Easy Aimer flange version 80mm/3"

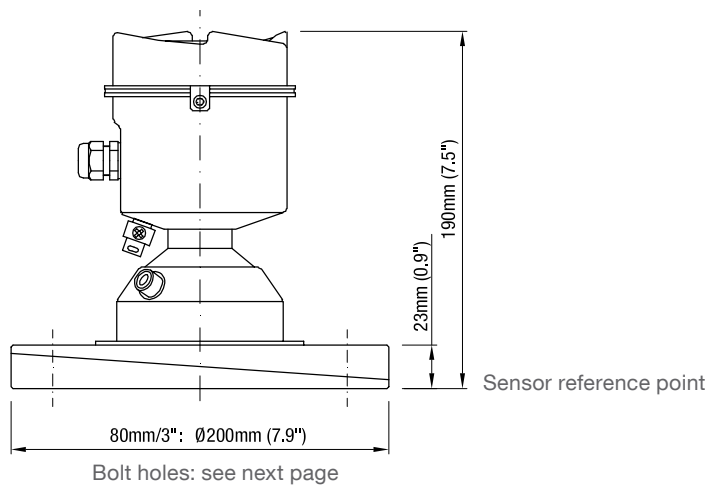

Easy Aimer flange version 100mm/4" 150mm/6"

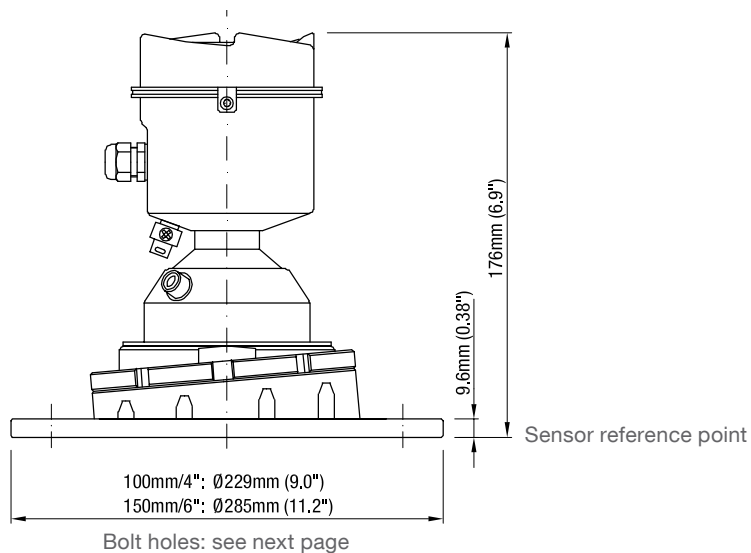

Dimensions / Options

Flanges

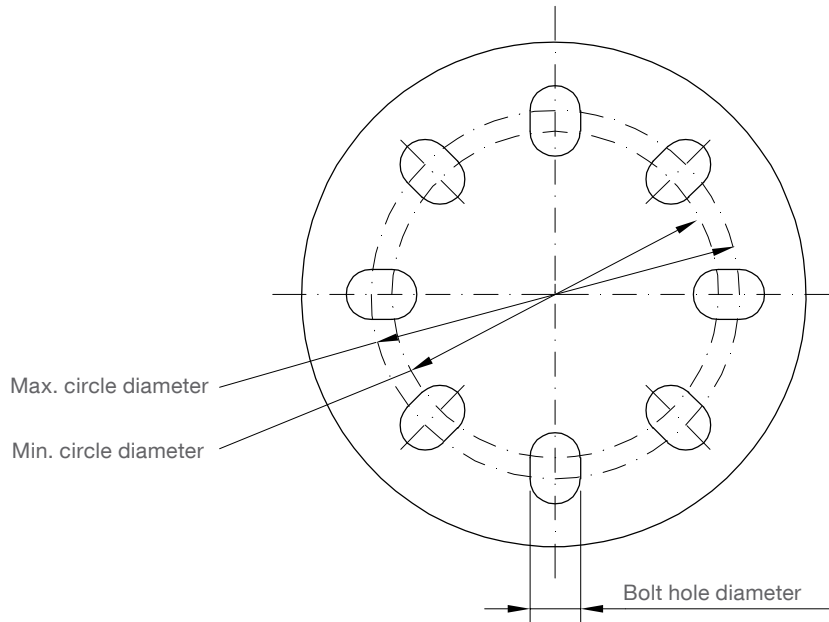

Universal flange (plane flange and Easy Aimer flange) mates with bolt hole pattern of:
 EN 1092-1 (PN16)
 ASME B16.5 (150 lb)
 JIS 2220 (10K)

Pipe size	Max. circle diameter	Min. circle diameter	Bolt hole diameter	Number of bolt holes
80mm/3"	160mm (6.30")	150mm (5.91")	19.3mm (0.76")	8
100mm/4"	191mm (7.52")	175mm (6.89")	19.3mm (0.76")	8
150mm/6"	242mm (9.53")	240mm (9.45")	23mm (0.90")	8

Options

Sun protection cover

If the unit is used outdoors, the use of the sun protection cover is recommended. It protects the device from excessively high temperatures.

Material: Stainless steel 1.4301 (304)

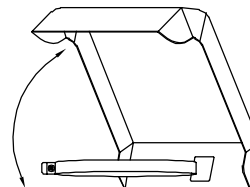

Mounting kits

Sealings, screws and washers for mounting the unit on a flange

Technical data

Electrical data

Power supply 4-20 mA loop power
 Nominal 24V DC (16.5 .. 30V DC)

4-20mA output Accuracy ± 0.02 mA

Upper limit 20 to 22.6 mA adjustable
 Lower limit 3.56 to 4 mA adjustable
 Fail signal 3.56 mA to 22.6 mA; or last value

Max. loop resistance	Loop voltage	Max. loop resistance
	16.5V	250 Ohm
	24V	550 Ohm
	30V	800 Ohm

Communication HART Max. line length: multi-wire: ≤ 1500 m (4921 ft)
 (depending on wire type. See www.hartcomm.org for more details)

Protocol HART, Version 6.0

Memory Non-volatile EEPROM (no battery required)

Connection terminals 0.34 .. 2.5 mm² (AWG 22 .. 14)

Cable entry 1 piece M20x1.5 or 1/2" NPT

Plug on display (inside housing) Removeable graphic LCD, with bar graph representing level.
 Display quality will be degraded in temperatures below -20 °C (-4 °F) and above +65 °C (+149 °F).

Mechanical data

Ingress protection Type 4X/NEMA 4X, Type 6/NEMA 6, IP68

Process connection **Plane flanges:**
 EN 1092-1 (PN16)/ASME B16.5 (150 lb)/JIS 2220 (10K) bolt hole pattern
 3"/80 mm, 4"/100 mm, 6"/150 mm
 Stainless steel 316L (1.4404 or 1.4435), or 304

Easy Aimer flanges:
 EN 1092-1 (PN16)/ASME B16.5 (150 lb)/JIS 2220 (10K) bolt hole pattern
 3"/80 mm, 4"/100 mm, 6"/150 mm
 Polyurethane powder-coated cast aluminum

Enclosure 316L/1.4404 stainless steel
 Lid with window (window material polycarbonate)

Lens antenna Material:
 40 m version: PEI
 100 m version: PEEK

Air Purge Connection Female 1/8" NPT fitting
 Non return valve (option, stainless steel, connection of 6mm tube diameter, opens at ca. 0.5 bar (7.25psi))

Weight 3" stainless steel flange model: 3.15 kg (6.94 lb)

Technical data

Operating conditions

Ambient temperature -40 .. +80 °C (-40 .. +176 °F)

Process temperature

40m version:
 -40°C .. +100°C
 (-40 .. +212°F)

100m version:
 -40°C .. +200 °C
 (-40 .. +392 °F)

Observe derating curve

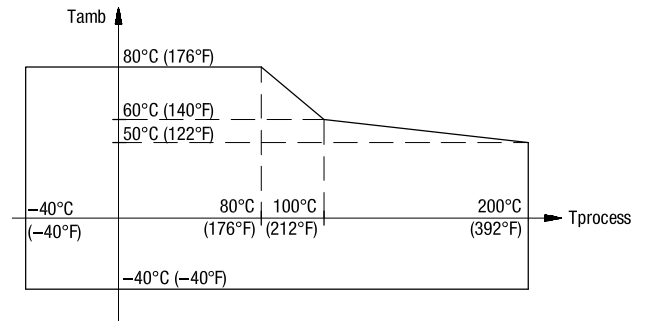

Process overpressure Depending on ordered version:
 -1 ..+0.5bar (-14.5 ..+7.2psi)
 -1 ..+3.0bar (-14.5 ..+43psi)

Ventilation Ventilation is not required

Polution degree 4

Installation category I

Relative humidity 0-100%, suitable for outdoor

Altitude max. 5000m (16.404ft)

Performance

Accuracy of measurement Maximum measured error:
 Greater of 25 mm (1") or 0.25 % of range from minimum detectable distance to full range

- Reference conditions:
 Position Detect (2.7.3.3.) set to Center and Algorithm (2.7.3.1.) set to True First Echo.
 Measured in accordance with IEC 60770-1:
- ambient temperature +15 to +25 °C (+59 to +77 °F)
 - humidity 45% to 75% relative humidity
 - ambient pressure 860 to 1060 mbar g (86 000 to 106 000 N/m² g)

Frequency / Beam angle 78 ..79 GHz FMCW / Beam angle 4°

Max. measurement range 40 m version: 40 m (131 ft)
 100 m version: 100 m (328 ft)
 From sensor reference point

Min. detectable distance 400 mm (15.7") from sensor reference point

Dielectric constant of material measured For ranges up to 20 m (65.6 ft): min. DK = 1.6
 For ranges up to 100 m (328 ft): min. DK = 2.5

Update time Maximum 10 seconds (Response Rate (2.4.1.) set to FAST)

Influence of ambient temperature < 0.003%/K (average over full temperature range, referenced to maximum range)

Technical data

Transport and Storage

Transport	Observe the instructions as stated on the transport packaging, otherwise the products may get damaged. Transport temperature: -40 .. +80 °C (-40 .. +176 °F) Transport humidity: 20 .. 85 % Transport incoming inspections must be carried out to check for possible transport damage.
Storage	Products must be stored at a dry and clean place. They must be protected from influence of corrosive environment, vibration and exposure to direct sunlight. Storage temperature: -40 .. +80 °C (-40 .. +176 °F) Storage humidity: 20 .. 85 %

Approvals

Hazardous Locations*	<p>Dust Ignition Proof: ATEX II 1D, 1/2D, 2D Ex ta IIIC IEC-Ex Ex ta IIIC T139°C Da FM/CSA DIP Class II, Div.1, Gr. E, F, G Class III</p> <p>Non-sparking/ Energy Limited: ATEX II 3G Ex nA II T4 Gc, Ex nL IIC T4 Gc IEC-Ex nA II T4 Gc, nL IIC T4 Gc, ta IIIC</p> <p>Non-incendive: FM/CSA NI Class I, Div.2, Gr. A,B,C,D</p>
-----------------------------	--

Ordinary Locations*	CE FM / CSA General purpose
EMC	EN 61326 -1 (industrial standard)
RoHS conformity	According to directive 2011/65/EU

Radio	R&TTE Compliance (Europe) FCC Conformity (US) Industry Canada
--------------	---

R&TTE Compliance (Europe)

Hereby, UWT GmbH, declares that the NR 3000 is in compliance with the essential requirements and other relevant provisions of Directive 1999/5/EC.
 The NR 3000 complies with EN 302 372 for use in closed storage vessels, when installed according to the installation requirements of EN 302 372, and may be used in all EU countries.
 The NR 3000 complies with EN 302 729 for use outside of closed tanks in EU countries. For open air installations, the following conditions must be observed:

- Installation and maintenance is performed by suitably qualified and trained personnel.
- The NR 3000 shall be installed only in a permanent fixed position pointing downwards. Its location shall comply with the following two restrictions:
 - 1) It shall be installed with a minimum separation distance of 4 km from Radio Astronomy sites listed at www.craf.eu/raobs.htm unless special authorization has been provided by the responsible national regulatory authority.
 - 2) If it is installed at a location between 4 and 40 km from any Radio Astronomy site listed at www.craf.eu/raobs.htm, the NR 3000 shall be installed at a height not exceeding 15m from the ground.

FCC Conformity (US)

US Installations only: Federal Communications Commission (FCC) rules:
WARNING: Changes or modifications not expressly approved by UWT GmbH could void the user's authority to operate the equipment.

Notes:

- This device has been tested and found to comply with the limits Class B digital device part 15 of the FCC Rules. These limits are designed to provide reasonable protection against harmful interference when the equipment is operated in a commercial environment.

* Depending on selected version in selection list

Technical data / Mounting

- This device has also been tested and found to comply with the limits §15.256, Subpart C-Intentional radiators, pursuant to Part 15 of the FCC Rules. These limits are designed to provide reasonable protection against harmful interference when the equipment is operated in a commercial environment.
- This device generates, uses, and can radiate radio frequency energy and, if not installed and used in accordance with the instruction manual, may cause harmful interference to radio communications, in which case the user will be required to correct the interference at his/her own expense.
- This device may be used to measure levels in fixed or mobile enclosed tanks.
- This device may be used to measure levels in open air environments or outside enclosed tanks, subject to the following conditions:
 - o Devices shall be installed and maintained to ensure a vertically downward orientation of the transmit antenna's main beam.
 - o Devices shall be installed only at fixed locations. Devices shall not operate while being moved or while inside a moving container.
 - o Hand-held applications and residential use are prohibited.

Industry Canada

The NR 3000 complies with Industry Canada standard RSS211 (March 2015).

- a) The installation of the NR 3000 shall be done by trained installers, in strict compliance with the manufacturer's instructions.
- b) The use of this device is on a "no-interference, no-protection" basis. That is, the user shall accept operations of high-powered radar in the same frequency band which may interfere with or damage this device. However, devices found to interfere with primary licensing operations will be required to be removed at the user's expense.
- c) The installer/user of this device shall ensure that it is at least 10 km from the Dominion Astrophysical Radio Observatory (DRAO) near Penticton, British Columbia. The coordinates of the DRAO are latitude 49°19'15" N and longitude 119°37'12" W. For devices not meeting this 10 km separation (e.g., those in the Okanagan Valley, British Columbia,) the installer/user must coordinate with, and obtain the written concurrence of, the Director of the DRAO before the equipment can be installed or operated. The Director of the DRAO may be contacted at 250-497-2300 (tel.) or 250-497-2355 (fax). (Alternatively, the Manager, Regulatory Standards, Industry Canada, may be contacted.)

Mounting

! General Safety Instructions

Process pressure	Improper installation may result in loss of process pressure. Never attempt to loosen, remove, or disassemble process connection or instrument housing while vessel contents are under pressure.
Chemical resistance against the medium	Materials of construction are chosen based on their chemical compatibility (or inertness) for general purposes. For exposure to specific environments, check with chemical compatibility charts before installing.
Mounting location	The right mounting place is significant for a proper function. Observe mounting instructions.
Sealings	The user is responsible for the selection of bolting and gasket materials which will fall within the limits of the flange and its intended use and which are suitable for the service conditions.

! Additional Safety Instructions for Hazardous Locations

Installation regulations	For devices to be used in Hazardous Locations the respective valid installation regulations must be observed.
Electrostatic charge	Parts of the enclosure may be non-conducting and may generate an ignitioncapable level of electrostatic charge under certain extreme conditions. The user should ensure that the equipment is not installed in a location where it may be subjected to external conditions (such as high-pressure steam), which might cause a build-up of electrostatic charge on non-conducting surfaces.

Mounting

Mounting instructions

Mounting position and aiming

- The unit is mounted vertically on top of the silo.
- Observe enough distance to the wall.
- Avoid central locations on tall, narrow vessels.
- A clear line of sight from the sensor to the product being monitored is required.
- Keep the sensor away from fill pipes, ladders, beams etc.

Aiming is strongly suggested for solid measurement. It helps to optimize the echo signal (mainly for low material level in the cone) and helps to solve not perfect mounting positions.

For proper mounting positions vertical installation without aiming is possible.

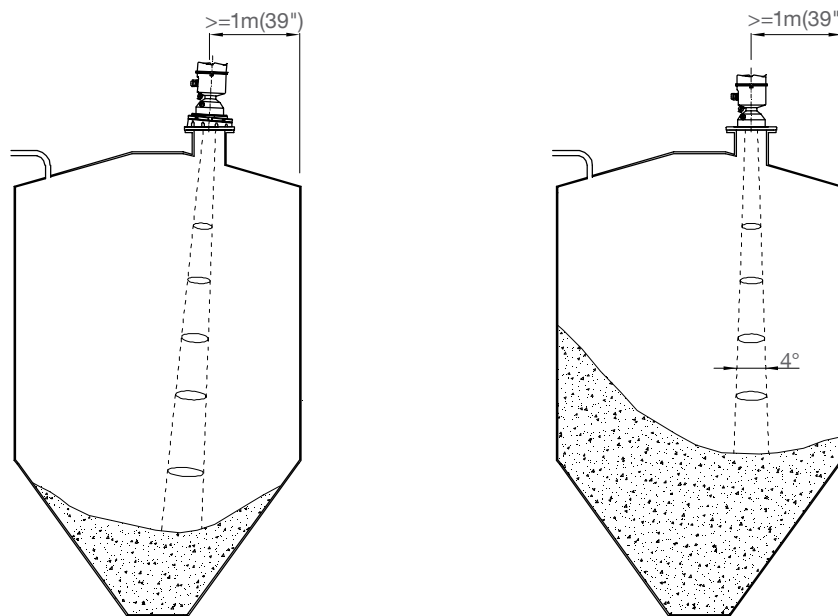

Easy Aimer adjustment

1. For the 80mm/3" Easy Aimer flange, tapered split washers with pressure rated versions are provided to keep nuts and bolts perpendicular to the flange surface.

For 100mm/4" and 150mm/6" Easy Aimer flange: Loosen the set screws in the locking ring. Holding the electronics enclosure firmly, loosen the Aimer locking ring using the supplied C spanner, until the unit drops down slightly. The enclosure can then be turned freely.

2. Direct the unit in the desired position and re-tighten the screws.

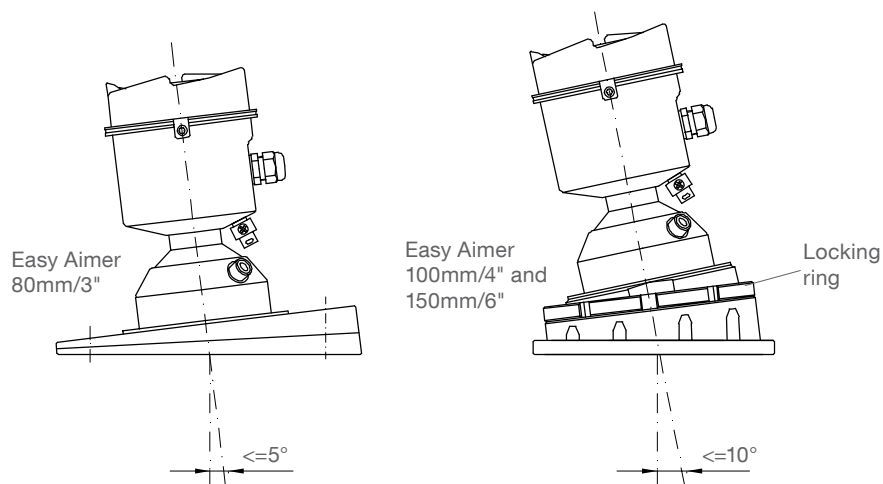

Mounting

Air Purging System

Use of air purging system

- The purge airflow is designed to create a strong vortex of air that rapidly cleans the face of the lens.
- The air purge system can clean both dust and moisture off the lens.
- It can be used for periodic cleaning.

Purge airflow

- The customer will supply the purging air by a manual or automatic valve system.
- Clean, dry air must be provided.
- Recommended 6.2 .. 7.6bar (90 ..110 psi) for effective cleaning.
- Air pressure in vessel can affect purge operation.

Notes:

- Purge duration, pressure, and interval, will vary with each application. It is the user's responsibility to determine the requirements depending on the application and cleaning required.
- Short duration bursts of high pressure provide more effective cleaning than continuous low pressure air.
- It is the customer's responsibility to ensure that any vacuum or pressure in the measured vessel is maintained, considering the hole that passes through the process connection and the antenna system.

Flow rate versus applied pressure:

Air Pressure	Approx. inlet volume flow rate
1.4bar (20 psi)	54 Nm ³ /h (5 SCFM*)
2.8bar (40 psi)	107 Nm ³ /h (10 SCFM*)
3.4 bar (50 psi)	161 Nm ³ /h (15 SCFM*)
5.5 bar (80 psi)	214 Nm ³ /h (20 SCFM*)
6.9 bar (100 psi)	268 Nm ³ /h (25 SCFM*)
7.6 bar (110 psi)	322 Nm ³ /h (30 SCFM*)

*standard cubic feet per minute

Purge Connection

- The purge connection is closed by the manufacturer.
- When the plug is removed to connect a purging system, the operator is responsible for ensuring that the purging circuit conforms to "Ex" requirements, for example, by fitting an NRV valve (non return valve). If applicable use the Non return valve offered by the manufacturer.

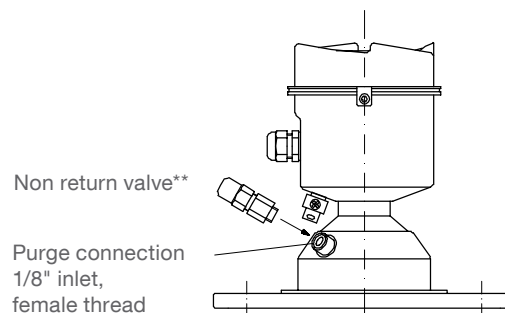

** Non return valve offered by the manufacturer:

- Stainless steel
- Connection of 6mm tube diameter
- Opens at ca. 0.5 bar (7.25psi)

Electrical installation

! General Safety Instructions

Handling	In case of improper handling or handling malpractice, the electric safety of the device cannot be guaranteed.
Installation regulations	The local regulations or VDE 0100 (Regulations of German Electrotechnical Engineers) must be observed.
Type plate	Check the type plate on your instrument to verify the approval rating.
Wiring diagram	The electrical connections are made in accordance with the wiring diagram.
Supply voltage	Compare the supply voltage applied with the specifications given on the name plate before switching the device on. The DC input terminals shall be supplied from a source providing electrical isolation between the input and output, in order to meet the applicable safety requirements of IEC 61010-1.
Cable gland	The screwed cable gland and closing element must have following specifications: Ingress protection IP68, temperature range from -40°C to +80°C, UL or VDE certified (depending on the country where the unit is installed), pull relief. Make sure that the screwed cable gland safely seals the cable and that it is tight (danger of water intrusion). The diameter of the field wiring cable has to match to the clamping range of the used cable gland.
Conduit system	In case of using a conduit system (with NPT thread) instead of a cable gland the regulations of the country, where the unit is installed, must be observed. The conduit must have a tapered thread NPT 1/2" in accordance with the unit and ANSI B 1.20.1.
Field wiring cables	Use twisted pair cable. The cross section has to match with the clamping range of the connection terminals. The temperature rating must be in accordance to the ambient temperature.
Guiding and connecting the cable in the terminal box	Cut the field wiring cables to appropriate length to fit properly into the terminal box. Strip the cable jacket for approximately 70 mm (2.75") from the end of the cable, and thread the wires through the gland.

! Additional Safety Instructions for Hazardous Locations

External equipotential bonding terminal

Connect to equipotential bonding of the plant

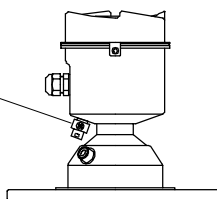

Field wiring	The equipment shall be installed such that the supply cable is protected from mechanical damage. The cable shall not be subjected to tension or torque. The equipment manufacturer is not responsible for providing the supply cable.
Cable glands for ATEX Hazardous Locations	The used entry devices and blanking elements must have an adequate type approval (protection concepts type 'n' or increased safety 'e' or flameproof 'd') and a temperature range as defined in the technical data of the unit. In addition they shall be suitable for the conditions and correctly installed. Where available the provided original parts of the manufacturer must be used.
Conduit system for FM Hazardous Locations	In addition the regulations of the country must be observed. The used flameproof seals and blanking elements must have an adequate type approval and a temperature range as defined in the technical data of the unit. In addition they shall be suitable for the conditions and correctly installed. Where available the provided original parts of the manufacturer must be used.
Supply rating	The supply to the equipment shall be rated for a prospective short-circuit current of not more than 10 kA and shall be protected by a suitably-rated fuse.
Further safety notes	See page 22.

Electrical installation

4-20mA

The terminals are located below the display. To connect the unit, remove the display by gently turning the display a quarter turn counter-clockwise until it is free.

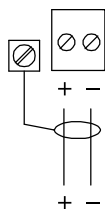

Use twisted pair cable: 0.34 mm² to 2.5 mm² (AWG 22 to 14)
 Connect cable shield to ground terminal

24V DC / 4-20mA loop

4-20mA HART

Typical PLC/mA configuration with HART:

- Depending on the system design, the power supply may be separate from the PLC, or integral to it.
- HART resistance (total loop resistance, that is, cable resistance plus 250 Ohm (external resistor) must be less than 550 Ohm @24V supply for the device to function properly.
- The external resistor is not required, if the PLC has an integral 250 Ohm resistor.

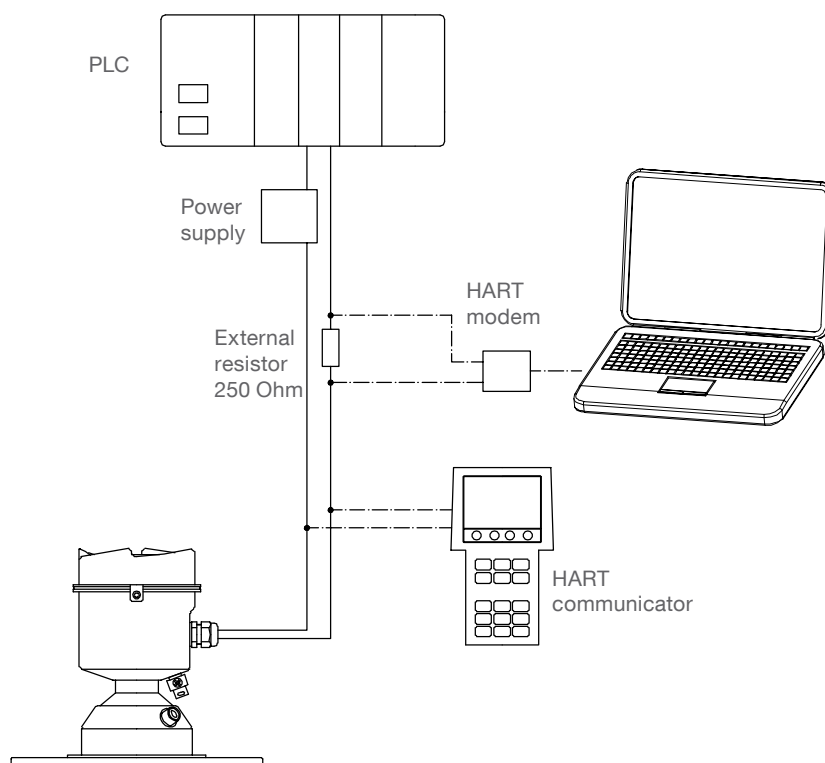

Programming

Overview

Plug on display

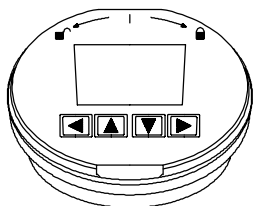

Programming is done with the "Plug on display".

The first time the device is configured, you will be prompted to select a language (English, German, French, Spanish or Chinese). Select language with **▼** and confirm by pressing **▶**.

Measurement mode

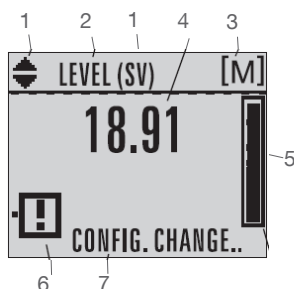

After power up the unit goes to Measurement mode. The required time to first measurement is less than 50 seconds.

Normal operation:

- 1 Not relevant*
- 2 Selected operation: level, space, or distance.
- 3 Selected units: m, cm, mm, ft, in.
- 4 Actual measured value (according to selected items 2 and 3).
- 5 Bar graph indicates level.
- 6 Device status indicator.
- 7 Device status text messages.

* Relevant with advanced programming. Toggle indicator for PV or SV (primary or secondary values). PV values represent the 4-20mA output (considering a programmed linearisation), SV values represent the pure measured values (without linearisation). Press **▲ ▼** to switch.



In case of fault:

- 6 Service required icon appears.
- 7 Text area displays a fault code and an error message.

Program mode

Display view

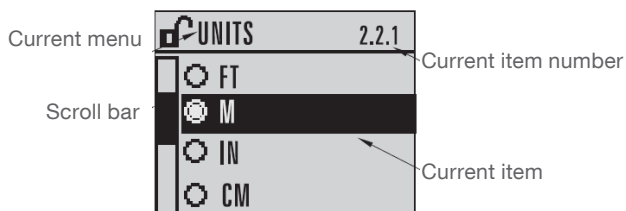

General procedure modify digits

Note: When the Enter **↵** icon is highlighted, press **▲** to insert a digit on the right, **▼** to delete the right-most digit, **▶** to accept the value, or **◀** to cancel.

1. Navigate to the parameter you wish to modify and press **▶** to edit it. The value will be highlighted.
2. Press **▲** or **▼** to delete the highlighted value, or **◀** to modify the value from the left-most digit, starting with the plus/minus sign.
3. With the plus or minus sign highlighted, press **▲** or **▼** to change it. Press **▶** to highlight the next digit to the right.
4. Use **▲** or **▼** to modify the highlighted digit. Scroll past 9 to reach the decimal point.
5. When the value is complete, press **▶** until the Enter **↵** icon is highlighted, then press **▶** to accept the value.

To modify a text string

1. Navigate to the parameter you wish to modify and press **▶** to edit it. The string will be highlighted.
2. Follow the same steps as above, to add, delete, or modify characters.

Programming

Quick Start

In Measurement mode press **▶** to enter Program mode.
 Choose Quick Start (1.), and then press **▶** to enter Quick Start Wizard (1.1).
 Press **▼** to jump to first Quick Start item "Vessel".

Vessel

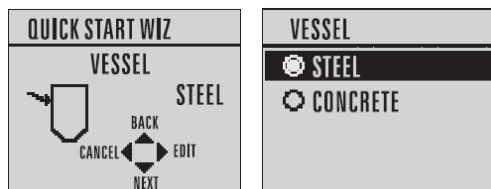

Select vessel construction material.

Options:
 Steel *
 Concrete

Response Rate

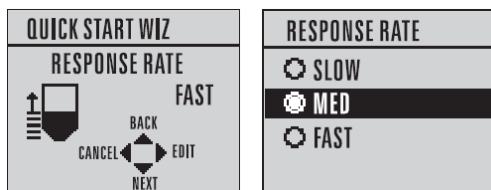

Sets the reaction speed of the device to measurement changes in the target range.

Response Rate	Vessel Fill Rate or Empty Rate
SLOW	0.1 m/min (0.32 ft/min)
MED *	1.0 m/min (3.28 ft/min)
FAST	10.0 m/min (32.8 ft/min)

Use a setting just faster than the maximum vessel filling or vessel emptying rate (whichever is greater).

Units

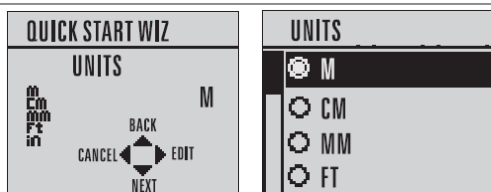

Sensor measurement units shown on the display.

Options:
 m *, cm, mm, ft, in

Operation

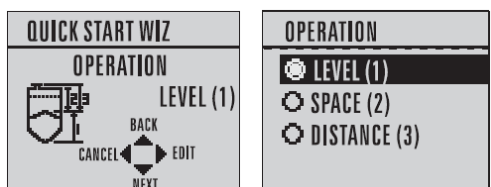

Operation	Description
LEVEL (1) *	Distance from Low Calibration Point to material surface
SPACE (2)	Distance from High Calibration Point to material surface
DISTANCE(3)	Distance from Sensor Reference Point to material surface

The 4-20mA output will be set accordingly, see drawing on next page.

Low calibration point

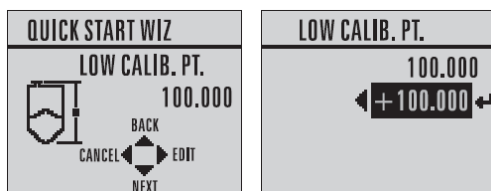

Distance from Sensor Reference Point to Low Calibration Point: usually process empty level.

Values Range: 0 to 40m/100m.

See drawing on next page.

High calibration point

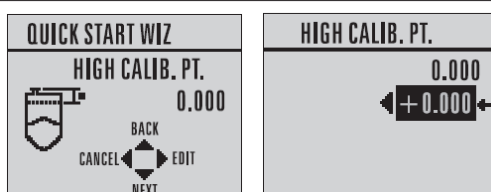

Distance from Sensor Reference Point to High Calibration Point: usually process full level.

Values Range: 0 to 40m/100m.

See drawing on next page.

To transfer Quick Start values to the device and return to Program menu, press **▼** (Finish).
 To ensure a safe measurement, go to page 17, "Check for safe measurement using echo profile"

* Factory setted values

Programming

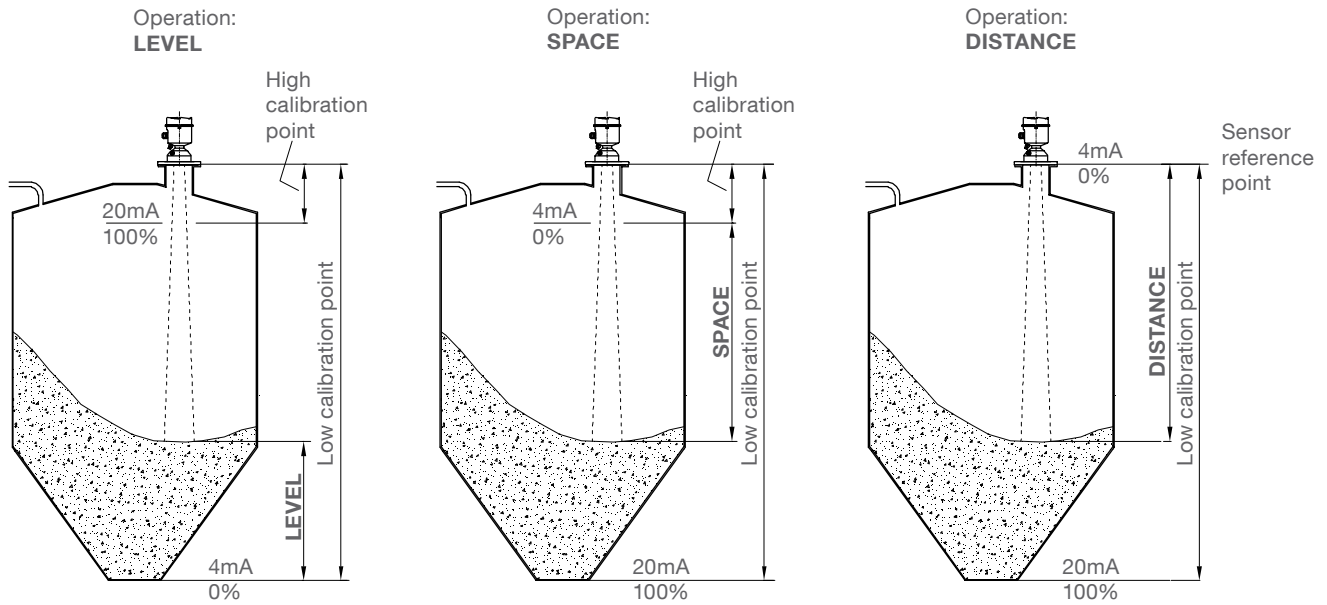

Programming

Check for safe measurement using echo profile

In Measurement mode press **▶** to enter Program mode.
 Choose Diagnostics (3.), and then Echo Profile (3.2.).
 Press **▶** to request a profile.

Displayed echo profile

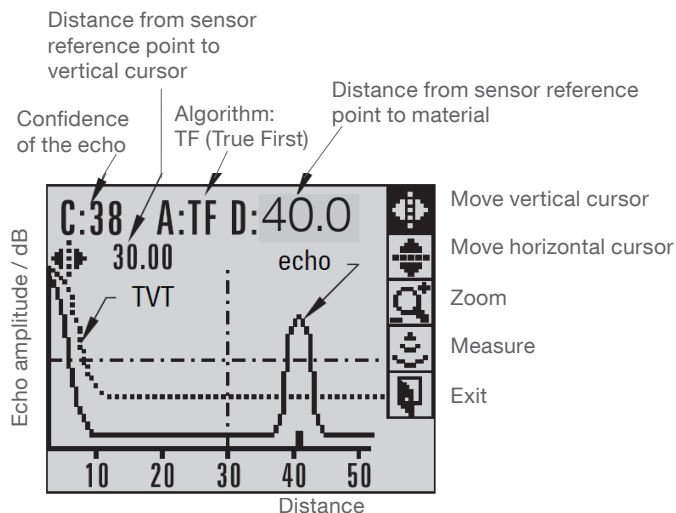

- Distance from sensor reference point to vertical cursor:
Allows to measure the exact distance of an echo.
- Algorithm TF (True First):
Standard setting. The first echo which is bigger than the TVT curve is considered as material level.
- Distance from sensor reference point to material:
Distance of the echo considered as material level.

To navigate in the echo profile

Use **▲** or **▼** to scroll to an icon. When an icon is highlighted, that feature becomes active.

To move a cursor, press **▶** to increase the value, **◀** to decrease.

To Zoom into an area, position the intersection of the cursor at the center of that area, select Zoom, and press **▶**. Press **◀** to Zoom out.

To update the profile, select Measure and press **▶**.

Checking the echo profile

Following items can easily be checked:

- Confidence of the echo needs to be ≥ 5 . If the value is smaller, the echo is too weak.
- Echoes in front of the material level echo need to be significant below the TVT curve. If an echo is present which is bigger than the TVT curve, it is considered as material level and causes a wrong measurement.

Possible improvements:

Check for proper mounting position (see chapter Mounting).

Check if sensor aiming helps to decrease such an echo (see chapter Mounting).

If no improvement is possible, contact manufacturer.

Return to Measurement mode

To return to the previous menu, select Exit, then press **▶**, then press **◀** to return to Measurement mode.

Programming / Trouble shooting

Copy of programmed parameters to other devices

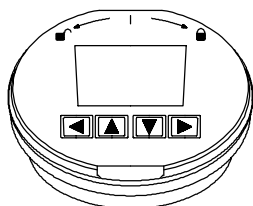

After a device is programmed, the parameters can be copied to other devices by loading the parameters into the "Plug on display", then remove the display from the device, insert it on another device and load the parameters into this device.

Copy parameters to "Plug on display"

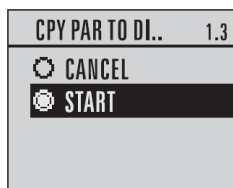
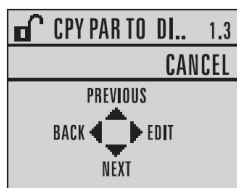

In Measurement mode press **▶** to enter Program mode.
 Choose Quick Start (1.), then CPY PAR TO DI (1.3). Press **▶**, then select START and press **▶**. PARAM UPLOAD is displayed, then the device returns to Measurement mode.

Copy parameters from "Plug on display" to a unit

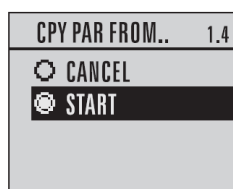
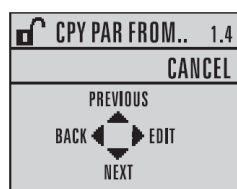

In Measurement mode press **▶** to enter Program mode.
 Choose Quick Start (1.), then CPY PAR FROM (1.4). Press **▶**, then select START and press **▶**. PARAM DOWNLOAD is displayed, then the device returns to Measurement mode.

Advanced programming and FDT (Pactware)

This is not part of this manual. Please refer to manufacturer for more information.

Trouble shooting

Failure description	Possible reason	Solution
Value jumps during measurement to 100% (indicating full vessel).	Reflections from mounting (e.g. socket)	<p>Ensure that at least 1,5m distance from sensor reference point to material level is present.</p> <p>In Measurement mode press ▶ to enter Program mode.</p> <p>Select SETUP (2.), TVT SETUP (2.8), AUTO ECHO SUPP (2.8.1) Go to LEARN and press ▶.</p> <p>The units states LEARN for some seconds. During this time echoes up to 1.0m distance are measured and as wrong echoes ignored.</p> <p>When the unit states ON, you can go back to measurement mode by pressing several times ◀.</p>

Description of further diagnostics is not part of this manual. Please refer to manufacturer for more information.

Menu structure

Menu structure

1. WIZARDS

- 1.1 QUICK START WIZ
 - VESSEL
 - RESPONSE RATE
 - UNITS
 - OPERATION
 - LOW CALIB. PT.
 - HIGH CALIB. PT.
- 1.2 AFES WIZ
- 1.3 COPY PARAMETERS TO DISPLAY
- 1.4 COPY PARAMETERS FROM DISPLAY
- 1.5 COPY FIRMWARE TO DISPLAY
- 1.6 COPY FIRMWARE FROM DISPLAY

2. SETUP

- 2.1 DEVICE
 - 2.1.1 LONG TAG
 - 2.1.2 TAG
 - 2.1.3 DESCRIPTOR
 - 2.1.4 MESSAGE
 - 2.1.5 INSTAL DATE
 - 2.1.6 HARDWARE REV
 - 2.1.7 FIRMWARE REV
 - 2.1.8 LOADER REV
 - 2.1.9 MENU TIMEOUT
 - 2.1.10 MANUF. DATE
- 2.2 SENSOR
 - 2.2.1 UNITS
 - 2.2.2 SENSOR MODE
 - 2.2.3 DAMPING FILTER
 - 2.2.4 TEMP. UNITS
 - 2.2.5 UNIT
- 2.3 CALIBRATION
 - 2.3.1 LOW CALIB. PT.
 - 2.3.2 HIGH CALIB. PT.
 - 2.3.3 SENSOR OFFSET
- 2.4 RATE
 - 2.4.1 RESPONSE RATE
 - 2.4.2 FILL RATE/MIN
 - 2.4.3 EMPTY RATE/MIN
- 2.5 FAIL-SAFE
 - 2.5.1 MAT. LEV
 - 2.5.2 TIMER
 - 2.5.3 LEVEL
- 2.6 ANALOG OUTPUT SCALE
 - 2.6.1 CURRENT OUTPUT FUNCTION
 - 2.6.2 4 MA SETPOINT
 - 2.6.3 20 MA SETPOINT
 - 2.6.4 MIN MA LIMIT
 - 2.6.5 MAX MA LIMIT
 - 2.6.6 MA OUTPUT MODE
 - 2.6.7 MANUAL VALUE
 - 2.6.8 MA OUTPUT VALUE
- 2.7 SIGNAL PROCESSING
 - 2.7.1 NEAR RANGE
 - 2.7.2 FAR RANGE

- 2.7.3 ECHO SELECT
 - 2.7.3.1 ALGORITHM
 - 2.7.3.2 ECHO THRESHOLD
 - 2.7.3.3 POSITION DETECT
 - 2.7.3.4 CLEF RANGE
 - 2.7.3.5 ECHO MARKER
- 2.7.4 SAMPLING
 - 2.7.4.1 ECHO LOCK
 - 2.7.4.2 UP SAMP.
 - 2.7.4.3 DOWN SAMP.
 - 2.7.4.4 ECHO LOCK WINDOW
- 2.7.5 FILTERING
 - 2.7.5.1 NARROW ECHO FILTER
 - 2.7.5.2 REFORM ECHO
 - 2.7.5.3 AVG AMOUNT
- 2.7.6 ECHO QUALITY
 - 2.7.6.1 CONFIDENCE
 - 2.7.6.2 ECHO STRENGTH

2.8 TVT SETUP

- 2.8.1 AUTO ECHO SUPP
- 2.8.2 AUTO SUPP RANGE
- 2.8.3 HOVER LEVEL
- 2.8.4 SHAPER MODE

2.9 TVT SHAPER

- 2.9.1 BREAKPOINT 1-9
- 2.9.2 BREAKPOINT 10-18
- 2.9.3 BREAKPOINT 19-27
- 2.9.4 BREAKPOINT 28-36
- 2.9.5 BREAKPOINT 37-45
- 2.9.6 BREAKPOINT 46-54
- 2.9.7 BREAKPOINT 55-63
- 2.9.8 BREAKPOINT 64-72
- 2.9.9 BREAKPOINT 73-81
- 2.9.10 BREAKPOINT 82-90
- 2.9.11 BREAKPOINT 91-99
- 2.9.12 BREAKPOINT 100-108
- 2.9.13 BREAKPOINT 109-117
- 2.9.14 BREAKPOINT 118-120

2.10 MEASURED VALUES

- 2.10.1 MAIN OUTPUT
- 2.10.2 O/P NO LINEAR
- 2.10.3 O/P NO OFFSETS

3. DIAGNOSTICS

- 3.1 FAULT RESET
- 3.2 ECHO PROFILE
- 3.3 TREND
- 3.4 PEAK VALUES
 - 3.4.1 MIN MEAS. VALUE
 - 3.4.2 MAX. MEAS. VALUE
 - 3.4.3 MINIMUM PV
 - 3.4.4 MAXIMUM PV
 - 3.4.5 MINIMUM SV
 - 3.4.6 MAXIMUM SV
- 3.5 ELECT TEMP
 - 3.5.1 MIN. VALUE
 - 3.5.2 MAX. VALUE
 - 3.5.3 INTERN. TEMP

Menu structure

- 3.6 REMAIN. DEV. LIFE
 - 3.6.1 TIME IN OPER
 - 3.6.2 REMAIN LIFETIME
 - 3.6.3 REMIND. 1 (REQ.)
 - 3.6.4 REMIND. 2 (DEM.)
 - 3.6.5 REMINDER ACTIVATION
 - 3.6.6 LIFETIME EXPECTED
 - 3.6.7 MAINT STAT
 - 3.6.8 ACK STATUS
 - 3.6.9 ACK

- 3.7 REMAIN. SENS LIFE
 - 3.7.1 TIME IN OPER
 - 3.7.2 REMAIN LIFETIME
 - 3.7.3 REMIND. 1 (REQ.)
 - 3.7.4 REMIND. 2 (DEM.)
 - 3.7.5 REMINDER ACTIVATION
 - 3.7.6 LIFETIME EXPECTED
 - 3.7.7 MAINT STAT
 - 3.7.8 ACK STATUS
 - 3.7.9 ACK

4. SERVICE

- 4.1 DEMO MODE
- 4.2 MASTER RESET
- 4.3 POWERED HOURS
- 4.4 POWERON RESETS
- 4.5 LCD BACKLIGHT
- 4.6 LCD CONTRAST
- 4.7 SERVICE SCHEDULE
 - 4.7.1 TIME LAST SERV
 - 4.7.2 TIME NEXT SERV
 - 4.7.3 REMINDER 1 (REQ)
 - 4.7.4 REMINDER 2 (DEM)
 - 4.7.5 REMINDER ACTIVATION
 - 4.7.6 SERVICE INTERVAL
 - 4.7.7 MAINT STAT
 - 4.7.8 ACK STATUS
 - 4.7.9 ACK
- 4.8 CALIB. SCHEDULE
 - 4.8.1 TIME LAST CALIB
 - 4.8.2 TIME NEXT CALIB
 - 4.8.3 REMINDER 1 (REQ)
 - 4.8.4 REMINDER 2 (DEM)
 - 4.8.5 REMINDER ACTIVATION
 - 4.8.6 CALIB INTERVAL
 - 4.8.7 MAINT STATUS
 - 4.8.8 ACK STATUS
 - 4.8.9 ACK

5. COMMUNICATION

- 5.1 DEVICE ADDRESS
- 5.2 REMOTE LOCKOUT

6. SECURITY

- 6.1 WRITE PROTECTION



7. LANGUAGE

Maintenance

General items

- Opening the lid (cover)**  Before opening the lid for maintenance reasons observe following items:
- No dust deposits or whirlings are present.
 - No rain can enter into the housing

- Frequent check of the unit**  To ensure durable safety in hazardous locations and with electrical safety, following items must be checked frequently depending on the application:
- Mechanical damage or corrosion of any components (housing side and sensor side) and of the field wiring cables.
 - Tight sealing of the process connection, cable glands and enclosure lid.
 - Properly connected external PE cable (if present).

- Cleaning**
- The unit requires no cleaning under normal operating conditions.
Under severe operating conditions, the antenna may require periodic cleaning.
If cleaning is required by the application, following must be observed:
-  • Cleaning agent must comply with the materials of the unit (chemical resistance). Mainly the lid, antenna material, sealing, cable gland and the surface of the unit must be considered.
 -  The cleaning process must be done in a way, that:
 - The cleaning agent cannot enter into the unit through the lid sealing or cable gland.
 - No mechanical damage of the lid sealing, cable gland or other parts can happen.
 - Remove the instrument from service and wipe the antenna clean using a cloth and suitable cleaning solution.
- A possible accumulation of dust on the unit does not increase the maximum surface temperature and must therefore not be removed for purposes of maintaining the surface temperature in hazardous locations.

- Production date** The production date can be traced by the serial number on the typeplate. Please contact the manufacturer or your local distributor.

- Spare parts** All available spare parts are stated in the selection list

Notes for use in Hazardous Locations

ATEX Zone classification

Category	Useable in zone	
1 D	20, 21, 22	* In case of conductive dust, additional requirements for installation are necessary.
2 D	21, 22	
3 D*	22	
3 G	2	

! Permitted zones (categories) for mounting in partition wall

EPL (IEC-Ex)	Db	Gc	
Category (ATEX)	2D	3G	
Zone	21	2	
EPL (IEC-Ex)	Da	Gc	
Category (ATEX)	1D	3G	
Zone	20	2	

! General notes

Marking / assembly

Devices with Ex-approval are marked on the type plate. For use and assembly and details of marking/coding, refer to the main instructions

POTENTIAL ELECTROSTATIC CHARGING HAZARD DO NOT CLEAN WITH DRY CLOTH DO NOT INSTALL WHERE BUILD-UP OF CHARGE IS LIKELY USE SUITABLY RATED CABLE DE-ENERGIZE BEFORE REMOVING COVER	<p>Sira 15ATEX4353X Ex nA II T4 Gc U_n = 32 V Ex nL IIC T4 Gc U_i = 32 V I_i = 22.63 mA C_i ≤ 5 nF L_i ≤ 20 μH</p>	<p>Ex ta IIIC T139 °C Da SIRA 15ATEX9352X IECEx SIR 15.0128X Ex ta IIIC T139 °C Da</p>	<p>NivoRadar NR 3000 NR 3100 xxxxxxx SERIAL NO.: GYZ / A 1034567 ENCLOSURE: NEMA / TYPE 4X, 6; IP68 AMB. TEMP.: -40°C to 80°C INPUT: 24 V \equiv NOM., 30 V \equiv MAX., 4 - 20 mA HART</p> <p>UWT LEVEL CONTROL, BETZIGAU, GERMANY Assembled in Canada with domestic and imported parts</p>	<p>CLASS II, DIV. 1, GR. E, F, G CLASS III, T4 CLASS I, DIV. 2 GR. A, B, C, D TEMP CODE: T4 REFER TO INSTALLATION DWG. A5E36968501</p>	<p>IC: 20874-NR3000 FCC ID: 2AF8D-NR3000 THIS DEVICE COMPLIES WITH PART 15 OF THE FCC RULES. OPERATION IS SUBJECT TO THE FOLLOWING TWO CONDITIONS: 1) THIS DEVICE MAY NOT CAUSE HARMFUL INTERFERENCE AND 2) THIS DEVICE MUST ACCEPT ANY INTERFERENCE RECEIVED, INCLUDING INTERFERENCE THAT MAY CAUSE UNDESIRABLE OPERATION</p>
---	---	---	---	---	--

Process pressure The device construction allows process over-pressure up to +0.5bar or 3bar (7.5 or 40psi). This pressure is allowed for test purposes. The definition of the Ex approvals are only valid for a silo-over-pressure between -0.2 .. +0.1 bar (-2.9 .. +1.45psi). Outside of these pressure the approvals are not valid.

Process and ambient temperature The equipment is certified for use in an ambient temperature range of -40 °C to 80 °C. The permitted temperature range is as well marked on the type plate.

Safety related device The equipment has not been assessed as a safety related device (as referred to by Directive 94/9/EC Annex II, clause 1.5).

Repair Repair of this equipment shall be carried out by suitably trained and authorized personnel in accordance with the applicable code of practice.

Notes for use in Hazardous Locations

! Maximum Surface Temperature

The maximum surface temperature refer to the warmest area outside on the unit which can occur in failure case (according to Ex definition).

Refer to the applicable code of practice for selection of this equipment with respect to specific dust ignition temperatures.

Max. Ambient temperature	Max. Surface temperature
80°C (176°F)	139°C (282°F)

! Installation Drawing Class I Div.2

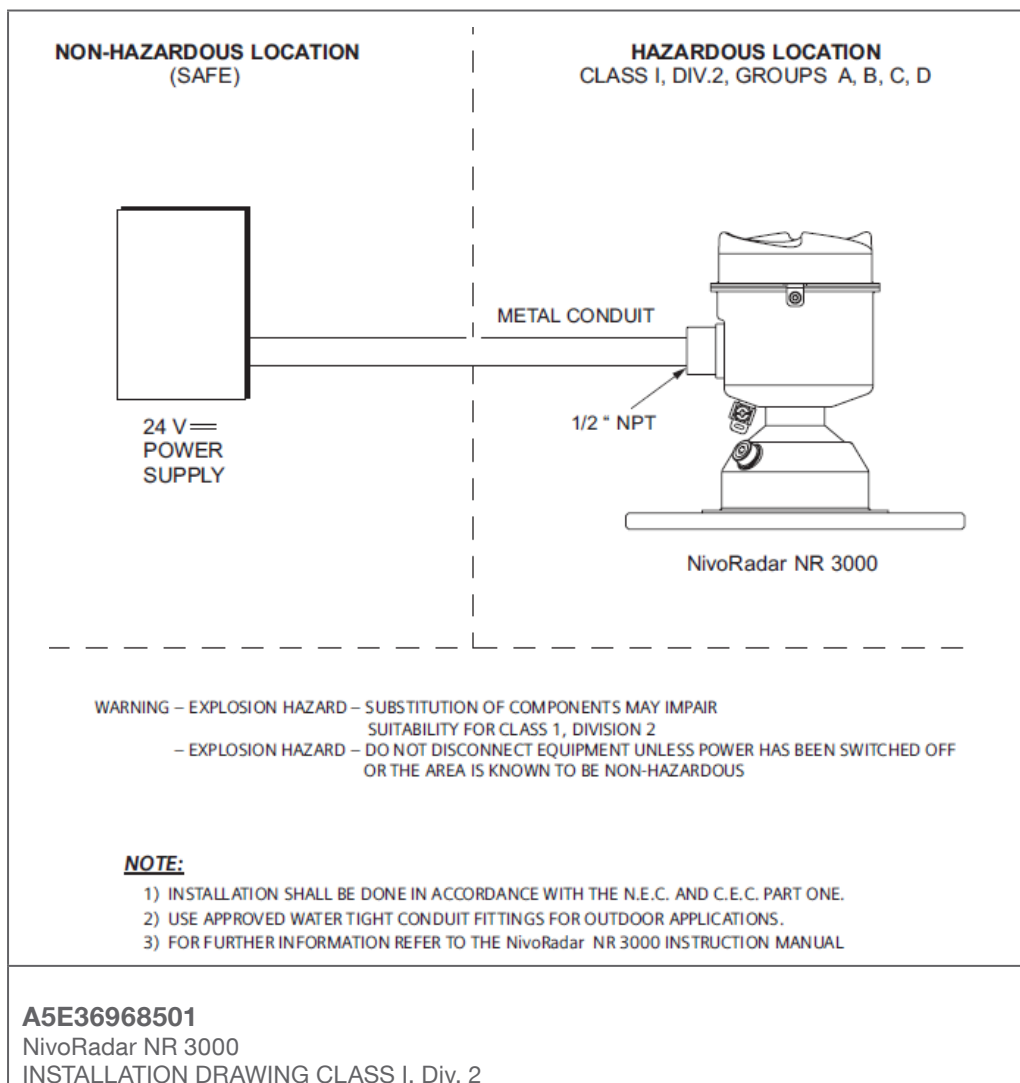

Disposal

The product consists of materials which can be recycled, details of the used materials see chapter "Technical data - mechanical data".

Recycling must be done by a specialised recycling company. Since the product is not subject to the WEEE directive 2002/96/EG, it is not permitted to bring it to a public recycling station.