



Differential Pressure Flow Meter/Monitor



measuring
•
monitoring
•
analysing

RCD



- Measuring ranges:
0.5 - 3.3 ... 300 - 2350 L/min water
0.5 - 5.35 ... 300 - 2750 m³_N/h air
- Accuracy: ± 3% of full scale
- p_{max} PN 40, t_{max} 100 °C
- Connection:
G 1/2...G 3, 1/2 NPT...3 NPT
- Material:
aluminum bronze and stainless steel



KOBOLD companies worldwide:

ARGENTINA, AUSTRIA, BELGIUM, BULGARIA, CANADA, CHILE, CHINA, COLUMBIA, CZECHIA, DOMINICAN REPUBLIC, EGYPT, FRANCE, GERMANY, GREAT BRITAIN, HUNGARY, INDIA, INDONESIA, ITALY, MALAYSIA, MEXICO, NETHERLANDS, PERU, POLAND, ROMANIA, SINGAPORE, SOUTH KOREA, SPAIN, SWITZERLAND, TAIWAN, THAILAND, TUNISIA, USA, VIETNAM

KOBOLD Messring GmbH
Nordring 22-24
D-65719 Hofheim/Ts.
Head Office:
+49(0)6192 299-0
+49(0)6192 23398
info.de@kobold.com
www.kobold.com

Description

The KOBOLD flow meter model RCD is used for measuring and monitoring liquid and gas flows. The device works on the well-known principle of the Venturi nozzle. A small pressure difference proportional to the flow is produced by the flowing medium at an orifice constriction (nozzle) in the device housing. The shape of the nozzle is based on the flow, whereby the flow characteristic remains constant over the entire measuring range. Drill holes are located in the housing fitting to absorb the resulting differential pressure and transfer it to a differential-pressure measuring cell fitted in the housing.

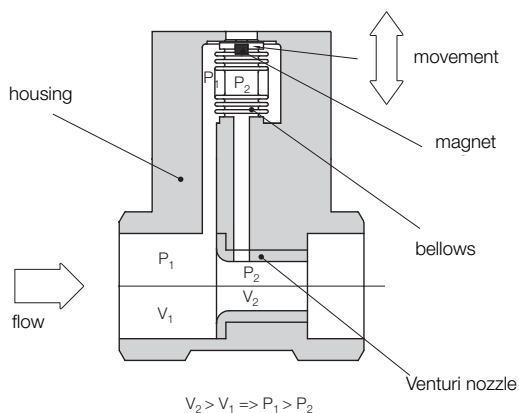

If the flow is exceeded the differential pressure measuring cell is protected by locking pins. On mechanical displays the flow rate measured by the pressure measuring cell is transferred via a pointer movement to the pointer indicator calibrated in L/min water or m³_N/h air. On electronic displays the mechanical motion is converted to an electrical signal by a Hall-sensor. Various electronic modules are then used to display and monitor the volumetric flow.

Special scales are available for all media at any pressure and any temperature.

Areas of Application

- machinery and equipment manufacturing
- chemical and pharmaceutical industries
- heavy industry
- beverage and semi-luxury food industry

Special advantages

- no moving parts
- mounting independant
- self-monitoring of measuring system
- Easy to use

Technical details

Measuring accuracy:	3 % of full scale
Repeatability:	1 % of full scale
Process temperature:	RCD... mechanical: 0...+100°C RCD... electronic: 0...+80°C
Ambient temperature:	max. 80 °C
Max. operating pressure:	25 bar (RCD-11 connection: G 3, 3 NPT) 40 bar (all others)
Pressure loss:	approx. 300 mbar
Minimum pressure:	0.6 bar
Protection:	IP 65
Materials:	
Display case:	cast aluminum
Front cover:	polycarbonate
Body:	RCD-x1...: aluminum bronze RCD-x2...: stainless steel 1.4581
Pressure measuring cell:	RCD-x1...: aluminum bronze RCD-x2...: stainless steel 1.4571
Pressure measuring cell:	stainless steel 1.4571
Venturi nozzle:	stainless steel 1.4571
Seals:	RCD-x1...: NBR RCD-x2...: FPM

Displays/ electronics:

- Mechanical pointer indicator

Display:	270°
Option:	special scales for other gases and liquids. Please specify meas. medium, density, viscosity, operating pressure and temperature
- Compact electronics

Display:	3-digit LED
Analogue output:	(0)4...20 mA adjustable, max. 500 Ω
Switching outputs:	1 (2) semiconductor PNP or NPN factory set
Contact operation:	N/C / N/O contact programmable
Setting:	via 2 buttons
Supply:	24 V _{DC} ± 20%, 3-wire, approx. 100 mA
Electrical connection:	plug connector M12 x 1
- ADI electronics

Display:	bar graph and 5-digit digital display
Analogue output:	(0)4...20 mA, 0-10 V _{DC}
2 switching outputs:	relay /changeover contact, max. 205 V _{AC} /5A resistive load, max. 30 V _{DC} / 5A
Setting:	via 4 buttons
Supply:	100 ... 240 V _{AC} ± 10 % or 18 ... 30 V _{AC} / 10 ... 40 V _{DC}
Electr. connection:	pluggable terminal block via cable gland

See brochure Z2 for more technical details on ADI evaluating electronics.



Order details (example: RCD 1195H G4 K 0 0 2)

Meas. range water [L/min]	Orifice Ø [mm]	Model		Connection	
		Material Alu. bronze	Material st. steel	G-thread	NPT
0.5...3.3	2.80	RCD 1195H	RCD 1295H	G4 = G ½	N4 = ½ NPT
0.5...4.2	3.15	RCD 1100H	RCD 1200H		
0.5...5.2	3.50	RCD 1190H	RCD 1290H		
1.0...6.8	4.00	RCD 1191H	RCD 1291H		
1.0...8.6	4.50	RCD 1101H	RCD 1201H		
1.0...10.6	5.00	RCD 1192H	RCD 1292H	G4 = G ½	N4 = ½ NPT
2.0...13.2	5.60	RCD 1102H	RCD 1202H		
2.0...16.8	6.30	RCD 1103H	RCD 1203H		
2.0...21.4	7.10	RCD 1104H	RCD 1204H	G5 = G ¾	N5 = ¾ NPT
3.0...27.0	8.00	RCD 1106H	RCD 1206H	G4 = G ½	N4 = ½ NPT
5.0...34.5	9.00	RCD 1109H	RCD 1209H	G5 = G ¾	N5 = ¾ NPT
5.0...42.5	10.00	RCD 1110H	RCD 1210H	G6 = G 1	N6 = 1 NPT
10.0...58.0	11.20	RCD 1114H	RCD 1214H	G5 = G ¾	N5 = ¾ NPT
10.0...66.0	12.50	RCD 1115H	RCD 1215H		
10.0...85.0	14.00	RCD 1116H	RCD 1216H		
20.0...118	16.00	RCD 1117H	RCD 1217H	G6 = G 1	N6 = 1 NPT
20.0...132	17.50	RCD 1125H	RCD 1225H		
20.0...148	18.00	RCD 1126H	RCD 1226H	G8 = G 1½	N8 = 1½ NPT
20.0...168	19.20	RCD 1130H	RCD 1230H	G8 = G 1½	N8 = 1½ NPT
30.0...275	26.00	RCD 1135H	RCD 1235H		
50.0...350	28.00	RCD 1137H	RCD 1237H	G9 = G 2	N9 = 2 NPT
50.0...435	31.00	RCD 1139H	RCD 1239H	G9 = G 2	N9 = 2 NPT
100...700	40.00	RCD 1145H	RCD 1245H		
100...910	43.50	RCD 1150H	RCD 1250H	GB = G 3	NB = 3 NPT
100...1060	51.00	RCD 1155H	RCD 1255H	GB = G 3	NB = 3 NPT
200...1540	60.00	RCD 1160H	RCD 1260H		
300...2350	67.00	RCD 1165H	RCD 1265H		

Evaluating electronics			
Mechanical pointer indication			
Indication	Flow direction	Location of indication	
Z = pointer indicator, 270°	L = from left R = from right B = from bottom	L = left R = right T = top B = bottom	
ADI-electronics**			
Indication	Supply	Output	Contacts
K = bargraph/digital	0 = 100-230 V _{AC/DC} 3 = 18-30V _{AC} , 10-40 V _{DC}	0 = without 4 = 0(4)-20 mA, 0-10V	2 = 2 changeover contacts
Compact electronics**			
Indication	Supply	Output/Contacts	
C = digital	3 = 24 V _{DC}	0R = 2 x open collector, PNP 0M = 2 x open collector, NPN 4P = 4-20 mA, 1 x open collector PNP 4N = 4-20 mA; 1 x open collector NPN	

Order details (example: RCD 1195L G4 K 0 0 2)

Meas. range air 1bar abs./20°C [m³ _N /h]*	Orifice Ø [mm]	Model		Connection	
		Material Alu. bronze	Material st. steel	G-thread	NPT
0.50...5.35	2.80	RCD 1195L	RCD 1295L	G4 = G ½	N4 = ½ NPT
1.00...6.70	3.15	RCD 1100L	RCD 1200L		
1.00...8.30	3.50	RCD 1190L	RCD 1290L		
1.00...10.9	4.00	RCD 1191L	RCD 1291L		
2.00...13.8	4.50	RCD 1101L	RCD 1201L		
2.00...17.0	5.00	RCD 1192L	RCD 1292L	G4 = G ½	N4 = ½ NPT
2.00...21.4	5.60	RCD 1102L	RCD 1202L		
3.00...27.0	6.30	RCD 1103L	RCD 1203L		
5.00...34.5	7.10	RCD 1104L	RCD 1204L	G5 = G ¾	N5 = ¾ NPT
5.00...43.5	8.00	RCD 1106L	RCD 1206L	G4 = G ½	N4 = ½ NPT
10.0...55.0	9.00	RCD 1109L	RCD 1209L	G5 = G ¾	N5 = ¾ NPT
10.0...68.0	10.00	RCD 1110L	RCD 1210L	G6 = G 1	N6 = 1 NPT
10.0...78.0	11.20	RCD 1114L	RCD 1214L	G5 = G ¾	N5 = ¾ NPT
10.0...97.0	12.50	RCD 1115L	RCD 1215L		
20.0...116	14.00	RCD 1116L	RCD 1216L		
20.0...158	16.00	RCD 1117L	RCD 1217L	G6 = G 1	N6 = 1 NPT
20.0...188	17.50	RCD 1125L	RCD 1225L		
20.0...198	18.00	RCD 1126L	RCD 1226L	G8 = G 1½	N8 = 1½ NPT
30.0...225	19.20	RCD 1130L	RCD 1230L	G8 = G 1½	N8 = 1½ NPT
50.0...375	26.00	RCD 1135L	RCD 1235L		
50.0...515	28.00	RCD 1137L	RCD 1237L	G9 = G 2	N9 = 2 NPT
100...630	31.00	RCD 1139L	RCD 1239L	G9 = G 2	N9 = 2 NPT
100...910	40.00	RCD 1145L	RCD 1245L		
200...1160	43.50	RCD 1150L	RCD 1250L	GB = G 3	NB = 3 NPT
200...1360	51.00	RCD 1155L	RCD 1255L	GB = G 3	NB = 3 NPT
400...2000	60.00	RCD 1160L	RCD 1260L		
300...2750	67.00	RCD 1165L	RCD 1265L		

Evaluating electronics			
Mechanical pointer indication			
Indication	Flow direction	Location of indication	
Z = pointer indicator, 270°	L = from left R = from right B = from bottom	L = left R = right T = top B = bottom	
ADI-electronics**			
Indication	Supply	Output	Contacts
K = bargraph/digital	0 = 100-230 V _{AC/DC} 3 = 18-30V _{AC} , 10-40 V _{DC}	0 = ohne 4 = 0(4)-20 mA, 0-10V	2 = 2 changeover contacts
Compact electronics**			
Indication	Supply	Output/Contacts	
C = digital	3 = 24 V _{DC}	0R = 2 x open collector, PNP 0M = 2 x open collector, NPN 4P = 4-20 mA, 1 x open collector PNP 4N = 4-20 mA; 1 x open collector NPN	

* m³_N/h correspond to a flow rate at 0°C; 1013 mbar ** Please specify flow direction in the order (except from top to bottom)
Please specify the operating conditions in the order

Dimensions

RCD...Z with mechanical display

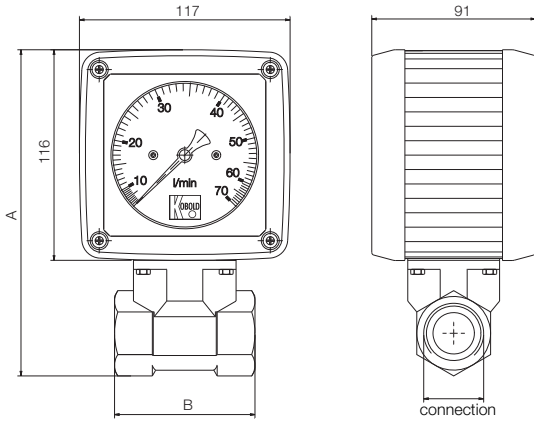

Thread	A	B	C	D	Weight
G 1/2	191	78	27 AF	143	approx. 2.0 kg
G 3/4	191	78	41 AF	143	approx. 2.3 kg
G 1	191	78	41 AF	143	approx. 2.2 kg
G 1 1/2	206	78	55 AF	158	approx. 2.6 kg
G 2	204	81	70 AF	156	approx. 2.8 kg
G 3	221	106	100 AF	173	approx. 5.1 kg

RCD...C with compact electronics

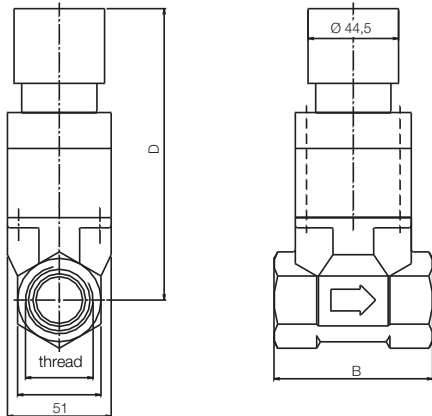

Thread	A	B	C	D	Weight
G 1/2	191	78	27 AF	143	approx. 2.1 kg
G 3/4	191	78	41 AF	143	approx. 2.4 kg
G 1	191	78	41 AF	143	approx. 2.2 kg
G 1 1/2	206	78	55 AF	158	approx. 2.6 kg
G 2	204	81	70 AF	156	approx. 2.9 kg
G 3	221	106	100 AF	173	approx. 5.2 kg

RCD...K with ADI-electronics

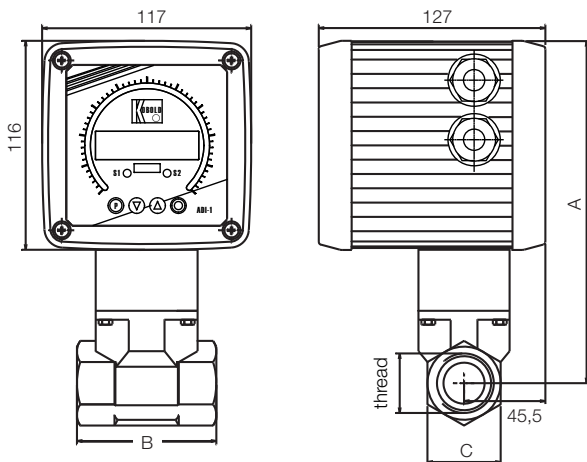

Thread	A	B	C	D	Weight
G 1/2	191	78	27 AF	143	approx. 3.4 kg
G 3/4	191	78	41 AF	143	approx. 3.7 kg
G 1	191	78	41 AF	143	approx. 3.6 kg
G 1 1/2	206	78	55 AF	158	approx. 3.9 kg
G 2	204	81	70 AF	156	approx. 4.2 kg
G 3	221	106	100 AF	173	approx. 6.5 kg