



Micro Flow Rate Measuring Transducer for Liquids



measuring
•
monitoring
•
analysing



Model: LFM...

- Measuring ranges:
0.005 - 0.250 L/min water
- Measuring accuracy:
 $\pm 2.5\%$ of measured value
- p_{max} : 100 bar, t_{max} : 70°C
- Viscosity range: 0.6 - 5 mm²/s
- Connection: G 1/8 female
and Swagelok 6 mm
- Material: St. St.
- Output: pulses



KOBOLD companies worldwide:

ARGENTINA, AUSTRIA, BELGIUM, CANADA, CHILE, CHINA, CZECHIA,
FRANCE, GERMANY, GREAT BRITAIN, INDIA, INDONESIA, ITALY,
MALAYSIA, MEXICO, NETHERLANDS, POLAND, SINGAPORE, SLOVAKIA,
SPAIN, SWITZERLAND, THAILAND, USA, VENEZUELA, VIETNAM

KOBOLD Messring GmbH
Nordring 22-24
D-65719 Hofheim/Ts.
☎ +49 (0) 61 92 299-0
Fax +49 (0) 61 92 233 98
E-Mail: info.de@kobold.com
Internet: www.kobold.com

Model:
LFM...



Areas of Application

The KOBOLD LFM is a new flow rate measuring transducer suitable for use in filling and batching processes with all types of low viscosity liquids. It can be used for extremely low volumetric flow rates > 0.005 L/min.

Typical Applications

- Additives
- Pharmaceuticals (good cleaning properties)
- Odorants/perfume
- Mains water and demineralized water
- Liquefied gases
- Food

Method of Operation

The measuring mechanism is based on a dual-ring piston pendulum. The right-hand measuring chamber is opened, and the left-hand chamber closed, by the pendulum arm that is inclined to the right. The pressure of the forced liquid acts on the upper surface of the piston pendulum. The right-hand ring piston is pressed clockwise downwards, and the left-hand ring piston is pressed clockwise upwards by the larger surface (opened measuring chamber) on the right.

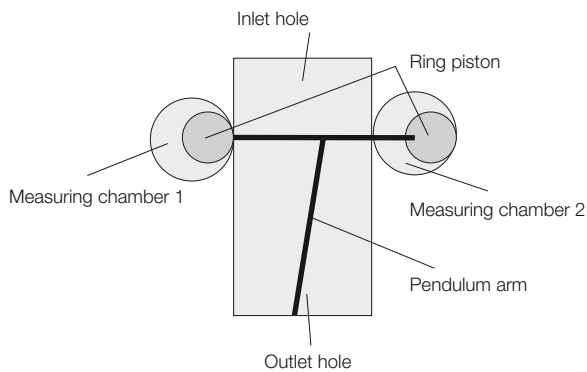

Thus the right-hand measuring chamber is closed, and the left-hand chamber opened. The surface on the left is now greater-causing motion in the opposite direction.

This cycle is repeated with continuous flow at a rate proportional to the flow rate 1-230 cycles/s.

A volume of approximately 0.01 cm³ is displaced per pass.

The built-in carrier frequency transducer senses the oscillating motion of the piston pendulum and pendulum arm without contact through the case, and outputs a digital signal with a frequency proportional to the volumetric flow.

Due to the negligible pendulum mass and minimum friction loss, the LFM detects minimum volumetric flow rates. Leakage loss is minimized by the piston design, which also provides good linearity and repeatability.

Digital indicators and transducers see end of brochure.

Technical Details

Linearity:	±2.5% of measured value
Repeatability:	0.1%
Viscosity range:	0.6 to 5 mm ² /s
K factor:	approx. 75000 imp./L
Frequency range:	5 to 230 Hz
Material:	Sensor housing: st. st. 14435 Pendular: st. st. 14122 Seal: FPM or PTFE
Electronic housing:	aluminium, anodized
Connection:	G 1/8 female thread (output) 6 mm Swagelok (input), NPT thread on request
Filter:	40 µm; filter with 6 mm Swagelok
Max. pressure:	100 bar
Max. Δp:	300 mbar at 5 cSt/0.25 L/min
Max. temperature:	70 °C (other upon request)
Electrical data:	passive NPN/OC $U_{high} = U_B$ $U_{low} < 0.6 V + (I_{out} [mA] \times 1.3 k\Omega)$ $U_{max} = 30 V$
Electrical conn.:	round plug incl. opposite plug
Installation position:	vertical, flow rate from bottom to top
Weight (with transducer):	approx. 650 g
Protection:	IP 65

Dimensions

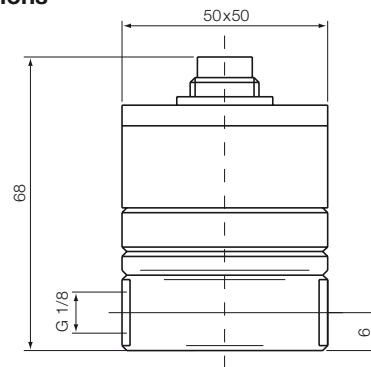

Electrical connection

Connector pin assignment:

- 1 = +U_B
- 2 = 0 V
- 3 = n. c.
- 4 = OC signal (collector)
- 5 = OC signal (emitter)

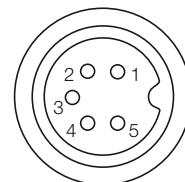

Order Details (Example: LFM-1040V)

Meas. ranges [L/min]	Material	Model	Gaskets
0.005-0.250	1.4435/1.4122	LFM-1040..	..V=FPM ..T=PTFE