

# KOBOLD Series DTM Digital Temperature Gauge

## User Instructions

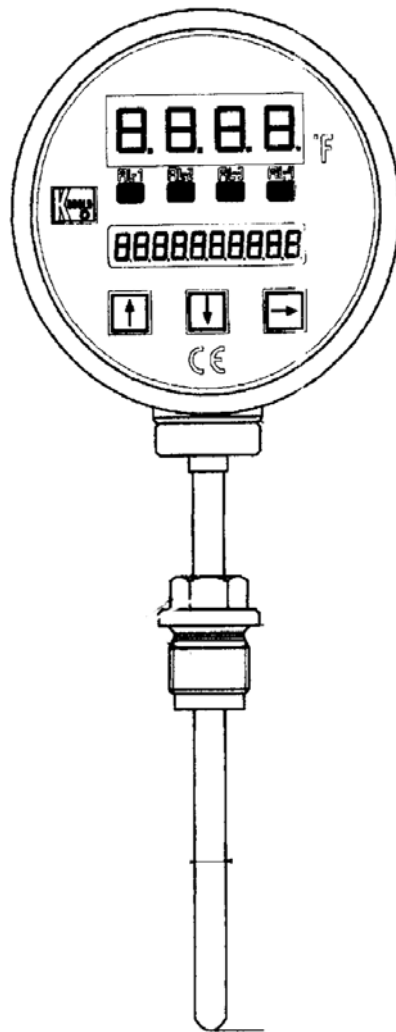

KOBOLD Instruments Inc. 1801 Parkway View Drive Pittsburgh PA 15205

Phone (412) 788-2830 • Fax (412)-788-4890 • [www.koboldusa.com](http://www.koboldusa.com)

**KOBOLD DTM DIGITAL TEMPERATURE GAUGE**

1.0 General ..... 1  
2.0 Specifications. .... 1  
3.0 Mechanical Installation. .... 3  
4.0 Electrical Connections ..... 4  
5.0 Operation ..... 5  
6.0 Maintenance. .... 9  
7.0 Need Help With Your DTM. .... 9

**List of Diagrams**

Diagram 2.1: Dimensions ..... 3  
Diagram 4.1: Wiring ..... 4  
Diagram 4.2: Power and Analog Output Connections ..... 4  
Diagram 5.1: DTM Displays and Controls ..... 5  
Diagram 5.2: Programming Flow Chart ..... 7

## KOBOLD DTM DIGITAL TEMPERATURE GAUGE

### User Instructions

**CAUTION:** For safety reasons, please read the cautionary information located at the end of the manual, before attempting installation.

#### 1.0 General

The DTM employs a Pt-100 resistive thermal device (RTD) sensing element whose resistance varies in proportion to a temperature change. This variable resistance signal is conditioned to provide an LED display and analog output. Optionally this meter can be provided with up to 4 switches whose switch points and hysteresis are programmable.

#### 2.0 Specifications

##### **General Specifications**

Ranges:	-30F to 750°F (see catalog for ranges)
Sensor Type:	Pt-100 RTD
Accuracy:	±0.5% of full scale ± 1 digit
Linearity:	±0.2% of full scale
Repeatability:	±0.1% of full scale
Operating Temperature:	
Medium:	Per Range Code
Ambient:	-5°F to 140°F
Storage:	-40°F to 160°F
Materials of Construction:	
Wetted Parts:	316 Ti-Stainless Steel
Housing:	304 Stainless Steel, Nylon

##### **Electrical Specifications**

Power Supply:	15-30 VDC, 300 mA Max. steady state, 1 AMP Inrush current
Analog Output:	
Current:	0-20 mA or 4-20mA, 3 wire into 500 ohms Max.
Voltage:	0-10 VDC into 500 Ohms Min.
Zero Adjust:	±25% of full scale
Optional Relays:	
Type:	SPDT, Qty. 0,2 or 4
Setpoints:	Fully Adjustable
Hysteresis:	Fully Adjustable
Max. Voltage:	250 VAC, 220 VDC
Max. Current:	3 Amps
Max. Power:	50 VA, 60 Watts

**Electrical Specifications** (continued)

## Displays:

Temperature: 4 digit, 0.5", Green LED

Switch Setpoints: 4 Digit Backlit LCD

Electrical Connections: Via Terminal Strip

Electrical Protection: NEMA 4/IP65

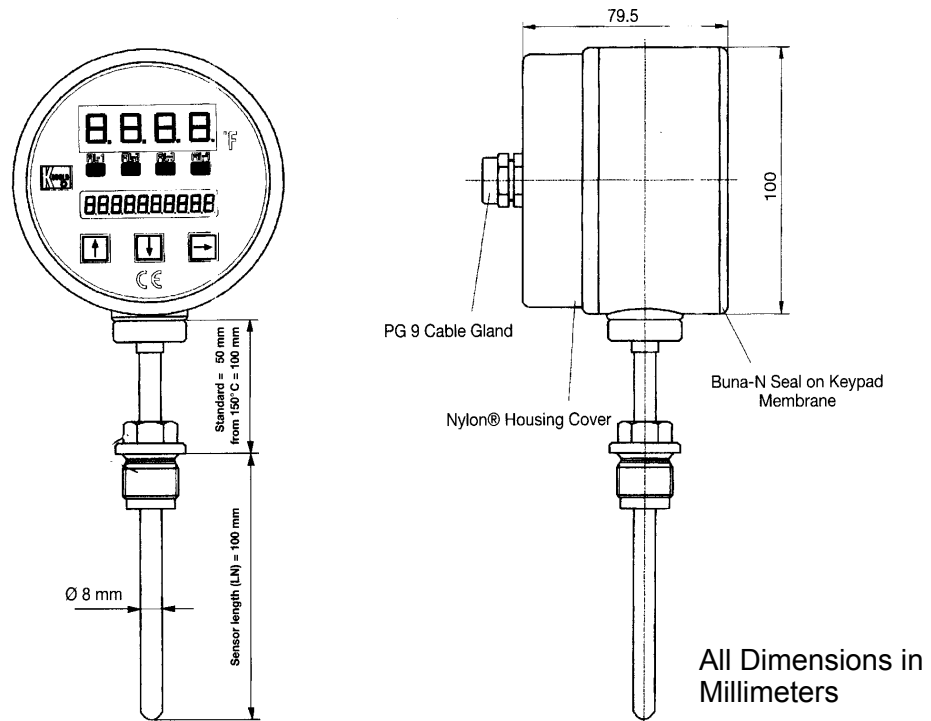
Diagram 2.1 Dimensions

### 3.0 Mechanical Installation

The following instructions and recommendations should be adhered to in order to ensure proper pressure gauge installation:

- 3.0.1 For the most accurate measurement, the gauge should be installed such that the probe tip is located at the center of the medium being measured
- 3.0.2 Install the gauge into a properly sized female port. Use of a thread sealant such as teflon tape is recommended to ensure a leaktight seal.
- 3.0.3 If it is desirable to remove the gauge from the process while the system is filled or pressurized. The gauge should be installed into a properly sized thermowell. Installing in a thermowell will increase the gauge response time. It is therefore recommended that a heat transfer paste is used inside the thermowell to minimize this negative effect
- 3.0.4 When tightening the gauge into the piping system use a properly sized wrench on the hex just above the threaded portion of the fitting. **Do not use the case of the gauge to apply torque or make or break the threaded connection as this may result in damage to the gauge.**

#### 4.0 Electrical Connections

1. The DTM requires a 15-30 VDC power supply with at least 300 mA steady state current capability. The unit has an inrush current of up to 1 Amp during the initial startup transient. It is therefore necessary to ensure that the power supply used with the DTM has a transient short-time current capability of at least 1 Amp.

2. The analog output signal wiring (if used) is made using either a **3-wire or 4-wire** connection as specified by the following wiring diagram:

**CAUTION: THE DTM IS NOT A LOOP POWERED (2-WIRE) DEVICE.**  
**DO NOT ATTEMPT TO USE A 2-WIRE CONNECTION AS THE**  
**INTERNAL ELECTRONICS WILL BE DAMAGED IMMEDIATELY!!!**

Diagram 4.1 Wiring

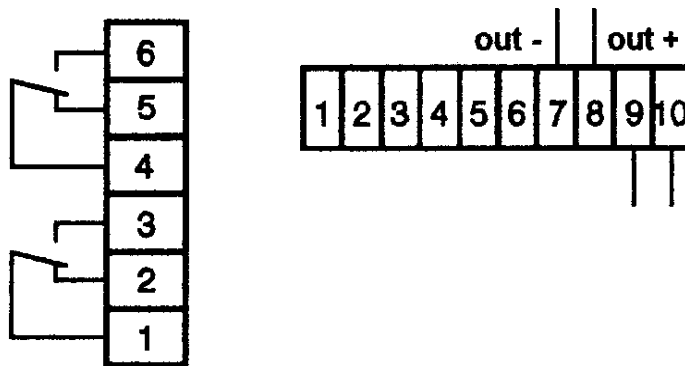

Note 1: Relays shown are optional

Note 2: Terminal blocks may be unplugged for wiring ease

Diagram 4.2: Power and Analog Output Connections

Terminal 10: DC Power (+)

Terminal 9: DC Power (-)

Terminal 8: Analog Output (+)

Terminal 7: Analog Output (-)

Terminals 1-6: Factory programming use only

## 5.0 Operation

Diagram 5.1 DTM Displays and Controls

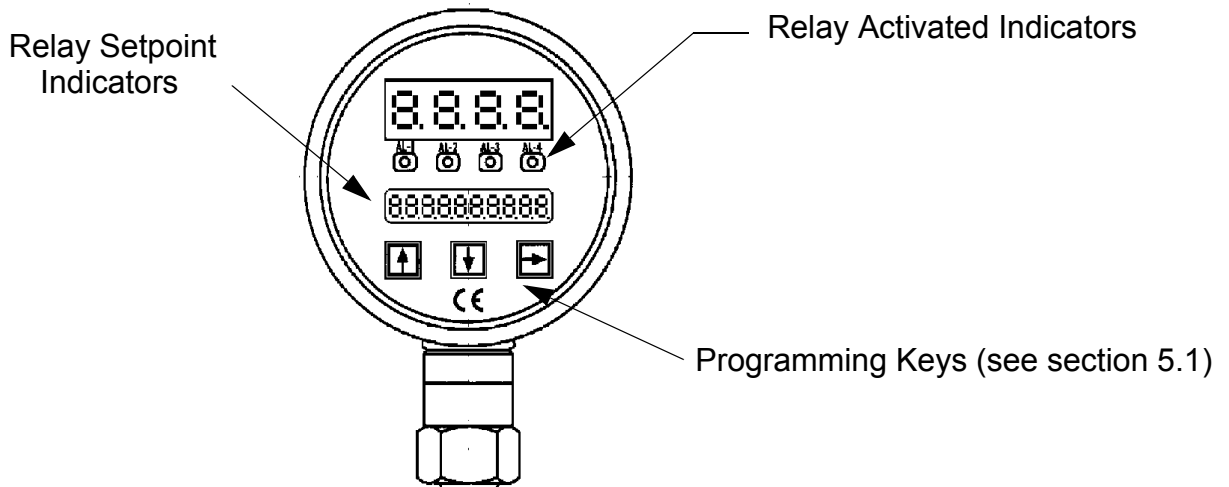

### 5.1 Programming, General

Programming is required in order to set the relay parameters and auto-zero the display if needed. The programming menu items are displayed on the LCD display below the main pressure display. The arrow keys on the front of the DTM are used to perform the programming as follows:

Depressing the  will place the DTM in the programming mode. **EO - EbEnE** will be displayed on the LCD display. There are 4 branches in the programming mode (see Diagram 5.2). Branch 1 sets Relay 1 parameters (setpoint, hysteresis etc.); Branch 2 sets the Relay 2 parameters; Branch three is used for auto-zeroing the display (not required for temperature instruments) and branch four is used only by the factory for initial setup. Menu items in branch 4 are locked and cannot be altered by the user.

Programming key functions when in the programming mode (refer to Diagram 5.2)



Move to the next menu item



Move to the previous menu item









Move to the next branch. (only when at the first menu item in a branch)



Go back to the operating mode

### 5.1 Programming, General (cont.)

When the numerical value of a menu item needs to be changed (e.g. changing relay setpoint value) pressing the  key will release the previous value to allow changing it. the far right digit will be flashing to signify that the setting has been released to be changed. Use  or  to change the value of that digit. Use  to toggle to the next digit. When the proper value is set, press  &  to enter the new value.

### 5.2 Programming Code Descriptions

The following is a listing of each programming code for the DTM along with a description of its function. Diagram 5.2 shows a flow chart of the programming process:















- E0 - EbEne      Programming mode enabled. Pressing  will toggle through each of the 4 programming branches (see Diagram 5.2).
- E0 - rELAiS1      Branch 1 for setting Relay 1 parameters. Use  to move to the next programming branch. Use  to move down through the Relay 1 branch and set the Relay 1 parameters of setpoint, hysteresis, and delay time.
- SPT1    XXXX      Relay 1 activation setpoint. To adjust the setpoint value, press the  key to release the previous setpoint value. the far right digit will be flashing to signify that the setting has been released to be changed. Use  or  to change the value of the flashing digit. Use  to toggle to the next digit. When the setpoint value is set, press  &  to enter the new value.
- HYS1    XXXX      Relay 1 hysteresis. Hysteresis is defined in this as the temperature setpoint where the relay de-activates. It is designed to allow for a temperature “deadband” between the relay activation and de-activation. To adjust the setpoint value, press the  key to release the previous setpoint value. the far right digit will be flashing to signify that the setting has been released to be changed. Use  or  to change the value of the flashing digit. Use  to toggle to the next digit. When the setpoint value is set, press  &  to enter the new value.









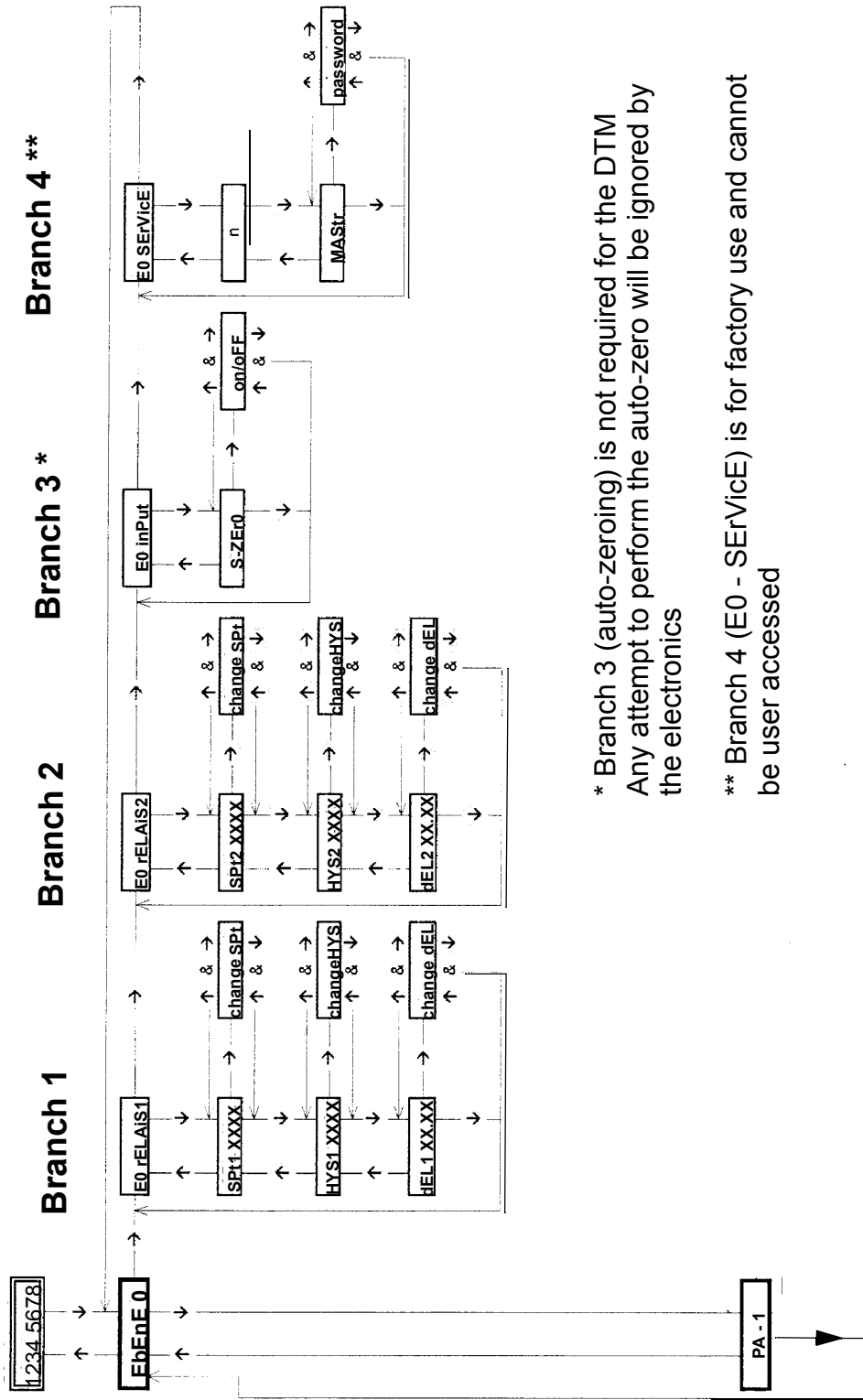









Diagram 5.2 Programming Flow Chart



\* Branch 3 (auto-zeroing) is not required for the DTM  
Any attempt to perform the auto-zero will be ignored by  
the electronics

\*\* Branch 4 (E0 - SERVicE) is for factory use and cannot  
be user accessed

## 5.2 Programming Code Descriptions (cont.)

- dE11 XXXX Sets the delay time in seconds for Relay 1 activation. To adjust the setpoint value, press the  key to release the previous value. The far right digit will be flashing to signify that the setting has been released to be changed. Use  or  to change the value of the flashing digit. Use  to toggle to the next digit. When the setpoint value is set,   &  to enter the new value.
- E0 - rELAiS2 Branch 2 for setting Relay 2 parameters. Use  to move to the next programming branch. Use  to move down through the Relay 2 branch and set the Relay 2 parameters of setpoint, hysteresis, and delay time. The parameters for Relay 2 are set in the same manner as those for Relay 1 above.
- E0 - inPUt Branch 3 for auto-zeroing the display. Auto-zeroing is not required for temperature gauges. Performing the auto-zero is ignored by the electronics and will have no effect on the unit.
- S - ZErO - OFF Enables auto-zero. Use  to enable auto-zero. "OFF" should flash. Use  to turn auto-zero on. "on" should flash. Use  &  to auto-zero. De-energize and re-energize the unit. The display should read zero.
- E0 - SErVicE Use only for factory setup. Use  to toggle back to E0 - EbEnE or  and  to return to the operating mode.

## 6.0 Maintenance

The DTM is an electronic device with no wear parts other than the relay contacts which if properly connected will last for several hundred thousand cycles. The only maintenance required on this device may be an occasional cleaning of the sensing probe if a coating or dirty process media exists. Possible indicators of a dirty sensing probe would be sluggish response to changes in process temperature.

## 7.0 Need Help With Your DTM?

Call one of our friendly engineers at (412) 788-2830

TERMINAL BLOCK/CONNECTOR  
REAR VIEW

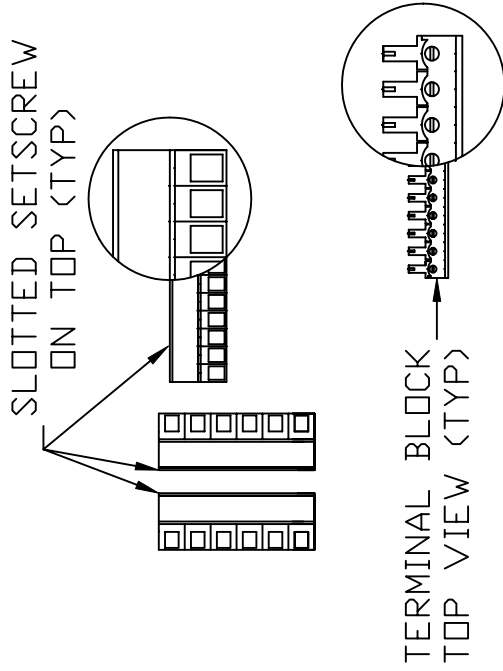

TERMINAL WIRING LABELING  
ENLARGED VIEW

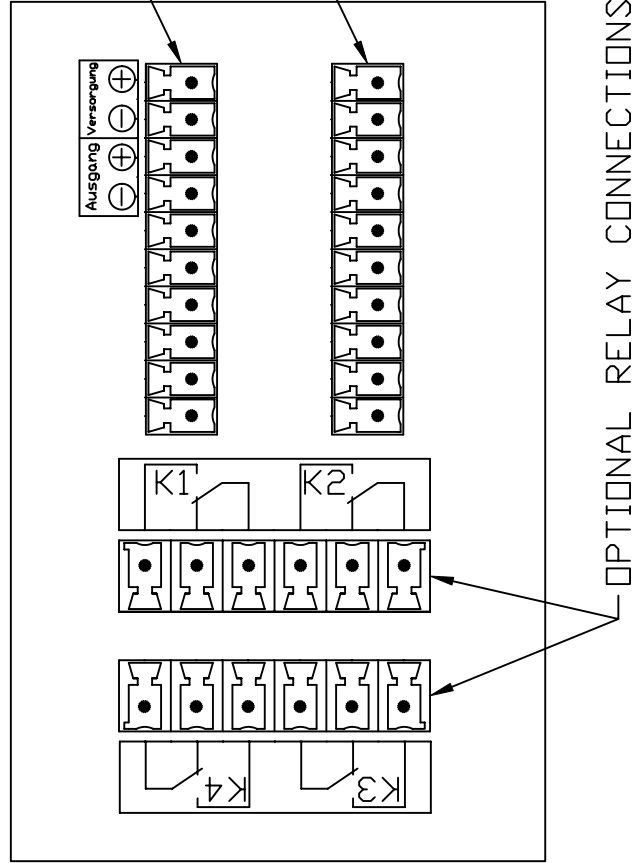

WIRING CONNECTIONS  
REAR VIEW

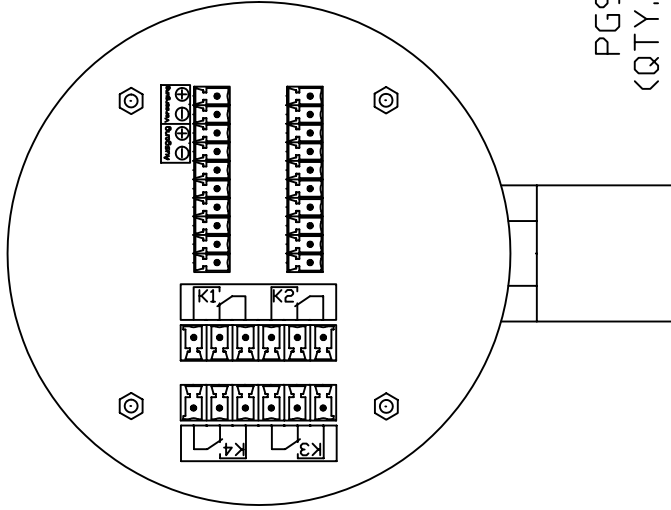

HOUSING/WIRING COVER  
REAR VIEW

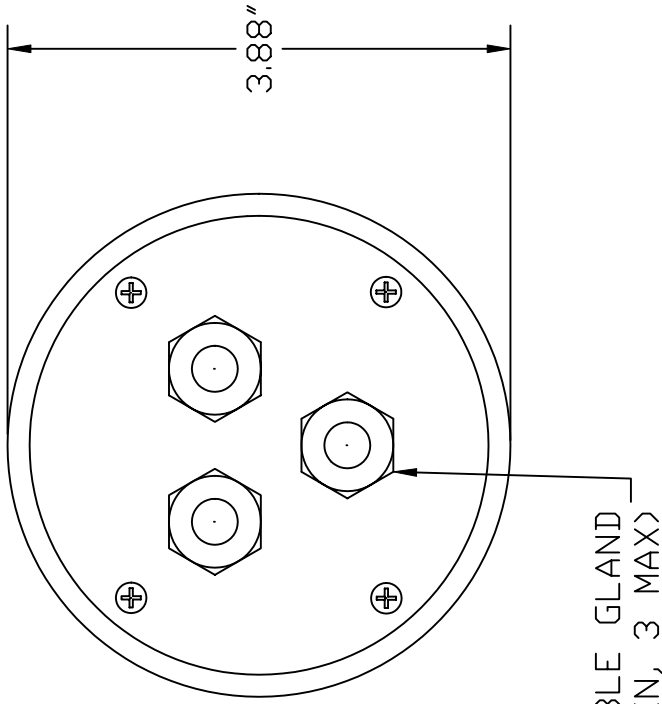

PG9 CABLE GLAND  
(QTY. 1 MIN, 3 MAX)

4-20 mA OUTPUT SIGNAL (LABELED "AUSGANG")  
15-30VDC @ 200mA POWER (LABELED "VERSORGUNG")  
(4 TERMINALS USED)

FACTORY PROGRAMMING ACCESS ONLY  
NO TERMINAL BLOCK PROVIDED/NO CONNECTION



KOBOLD INSTRUMENTS, INC.  
1801 Parkway View Drive  
Pittsburgh, PA 15205

MODEL: DSF\_TSF\_DTM

DATE: 02/24/04

DESCR: WIRING CONNECTION

REV: 1

SCALE: N/A DRAWN: EAS

DWG: dsf\_tsf\_dtm

OPTIONAL RELAY CONNECTIONS

**CAUTION**

PLEASE READ THE FOLLOWING WARNINGS BEFORE ATTEMPTING  
INSTALLATION OF YOUR NEW DEVICE. FAILURE TO HEED THE  
INFORMATION HEREIN MAY RESULT IN EQUIPMENT FAILURE AND  
POSSIBLE SUBSEQUENT PERSONAL INJURY.

- **User's Responsibility for Safety:** KOBOLD manufactures a wide range of process sensors and technologies. While each of these technologies are designed to operate in a wide variety of applications, it is the user's responsibility to select a technology that is appropriate for the application, to install it per these installation instructions, to perform tests of the installed system, and to maintain all components. The failure to do so could result in property damage or serious injury.
- **Proper Installation and Handling:** Use a proper sealant with all installations. Never overtighten the unit within the fitting. **Never use the housing to thread the unit into its fitting.** Always use only an appropriate sized wrench on the hex portion of the probe. Always check for leaks prior to system start-up.
- **Wiring and Electrical:** The sensor is designed to operate within the voltage and current limits listed in section 2.0, Specifications. The sensor systems should never exceed these ratings. Electrical wiring of the sensor should be performed in accordance with all applicable national, state, and local codes.
- **Temperature and Pressure:** The DTM is designed to operate within the temperature and pressure limitations listed in section 2.0, Specifications. Operation outside these limitations will cause damage to the unit and possible personal injury. Fluids should never be allowed to freeze inside the sensor mechanism. The expansion of the fluid which occurs when fluids freeze may cause damage to the sensing mechanism or probe.
- **Material Compatibility:** Check your model number with the wetted materials specification in Section 2.0, "Specifications", on page 1 of this manual. Make sure that the model which you have selected is chemically compatible with the application liquids. While the switch housing is liquid resistant when installed properly, it is not designed to be immersed. It should be mounted in such a way that it does not normally come into contact with fluid.
- **Flammable, Explosive and Hazardous Applications:** The DTM is not an explosion-proof design. It should not be used in applications where an explosion-proof design is required.
- **Make a Fail-safe System:** Design a fail-safe system that accommodates the possibility of switch or power failure as well as operator error. In critical applications, KOBOLD recommends the use of redundant backup systems and alarms in addition to the primary system.